

Build Your Own



CHALK EASEL



**Do It Yourself Designs for
Beginner & Practice Easels
Portable & Professional Easels
Large & Bedsheet Easels
Lighting & Wiring Diagrams**

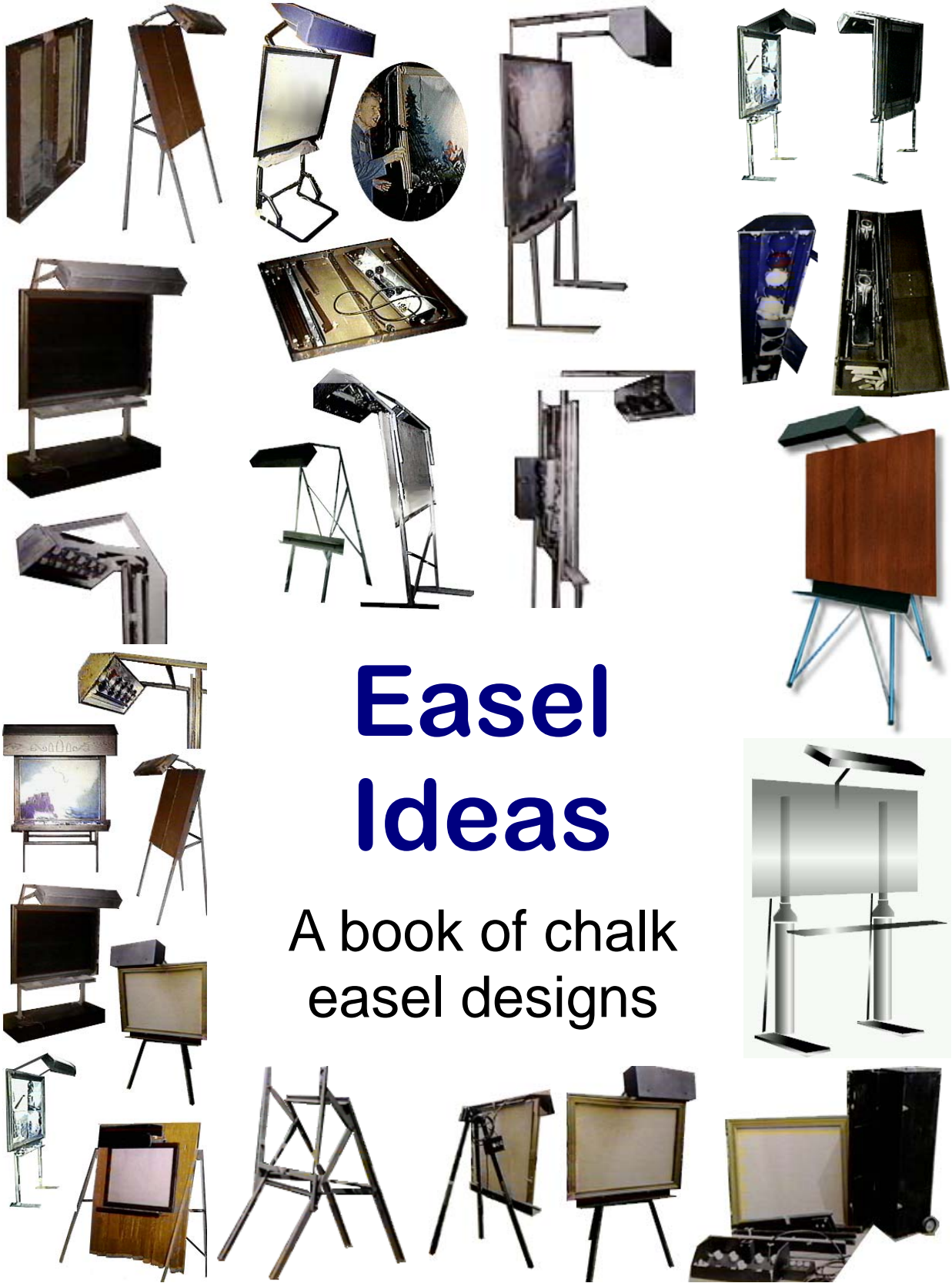

Easel Ideas

A book of chalk easel designs



Table of Contents

Preface	4
Introduction	5
Practice Easels	6
Tabletop Easels	9
Portable Easels	11
Bed Sheet Easels	33
Large Format Easels	37
Lighting	47

Preface

I have been at war with my equipment since my first drawing. Many of my easels seemed as if they were trying to run away from me as I drew on them. One would begin to sway and rock so wildly, I could hardly draw on it as it went by. I needed a special sound system just to drown out its groans and squeaks.

Another easel attacked me in the middle of my presentation by dropping a screen on my head. I wrestled it to the floor just in time for an over head glue bar to stick in my hair. I pulled long and hard to remove that bar. This produced a Mohawk hair style for the rest of the event.

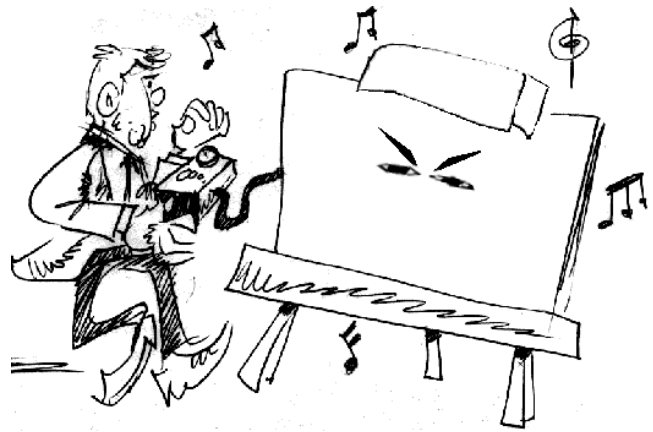

I must confess, I have often spent time praying for protection from my equipment. I have greatly enjoyed the stories of those miraculously delivered from their easel designs. Some designs make us wish US patents were easier to get, to protect others from the same mistakes. For this reason, this book is copyrighted.

I wish I could call this book, "Easels made easy", but there is nothing easy about making a sturdy, lightweight, portable easel with conventional tools and a limited budget. The best we can hope for is to share practical designs that have been effectively used over the last 60 years.



I hope you can avoid Avonelle Slagle's embarrassment. Her easel collapsed on top of her at the end of her drawing. As she laid there in the dark she said, "I seriously thought of pretending I was dead."





"The best part of any new endeavor, is that it involves the purchasing of a bunch of new stuff" - H. D. Thoreau

Chalk Art is centuries old. It is rich with a wonderful heritage of pioneers who carried their easels on horseback to the town square, the meeting hall and the church house. They easily captured the imagination with the simplest of tools.

Each artist discovers new ideas for equipment. Some insist their prototype is best yet rarely are two easels exactly alike. Some merit can be found in almost every design, if you look hard enough.

Since some artists sell plans and easels, only basic plans are presented here. This book is not meant to be a machinist hand book, carpentry guide or electrical wiring course. Instead it is a review of unique ideas for chalk easels.

The following pages present designs for **practice easels, tabletop easels, portable easels, bedsheet easels, large format easels and light hoods.** Most are tested patterns. Others are new, fresh ideas.



Figure 4

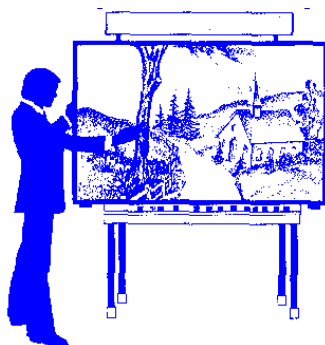

One of my first easels was made of 2 X 4's in a swing set shaped stand and a plywood drawing board. Note how the board, lights and tray appear to hang on air because of the curtains. This was an idea used by artist, Bill Leach.

Practice Easels

Most commercial easels are not sturdy enough for large format chalk work. The simplest practice drawing board is a smooth sheet of half inch plywood, solidly mounted to a wall. The best drawing paper is gray bogus. It comes in sheets that are 40" X 53". Practice on half sheets of paper is easier for the beginner. Paper must be taped, tacked or clamped securely to the board so no wrinkles, slippage or tears are possible. It is also a great idea to have several sheets under it to act as a smooth pad under the drawing sheet.

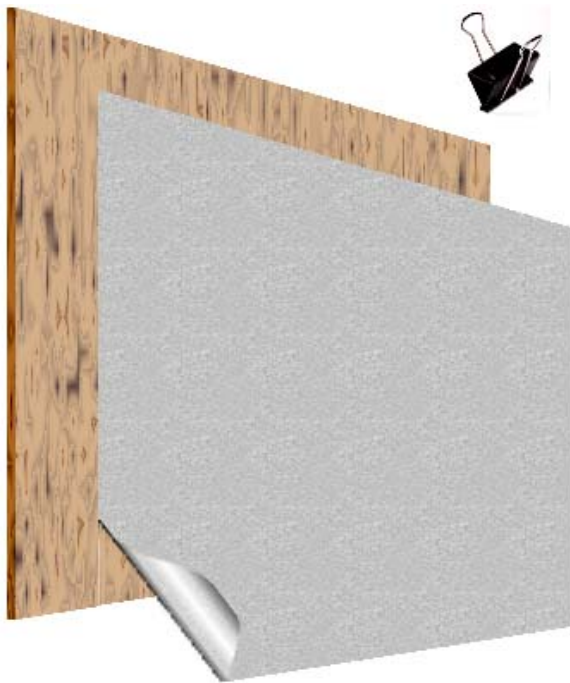

Tripod easel used by Bernie Murray as he draws onboard ship

Smith Practice Easel

This design was created by Robert Leonard Smith. Its removable leg and board fold for easy transport.

Parts:

Drawing board & leg brace - 1/2" Plywood
Legs and Tray - 1" X 4" s and 1" X 2" s

Assembly:

Order his book "Successful Chalk Talking" for details.

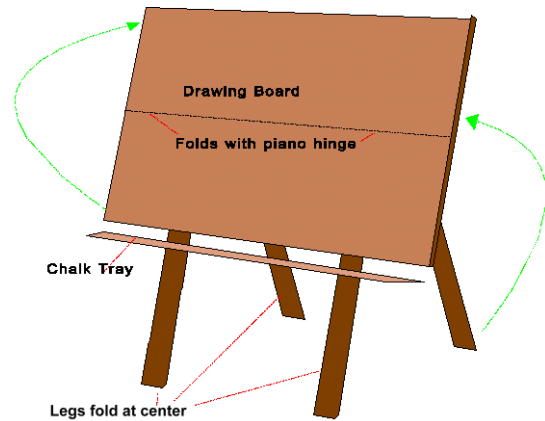

Teuling Practice Easel

This design was created by Ding and Dave Teuling (RD # 1 Wood Road, Muskegon, MI 49444). Remove the legs for transport.

Parts:

Drawing board & leg brace - 1/2" to 3/4" Plywood
Legs and Tray - 1" X 4" s and 1" X 2" s

Assembly:

Drywall Screws, Biscuit Joints or tongue & groove

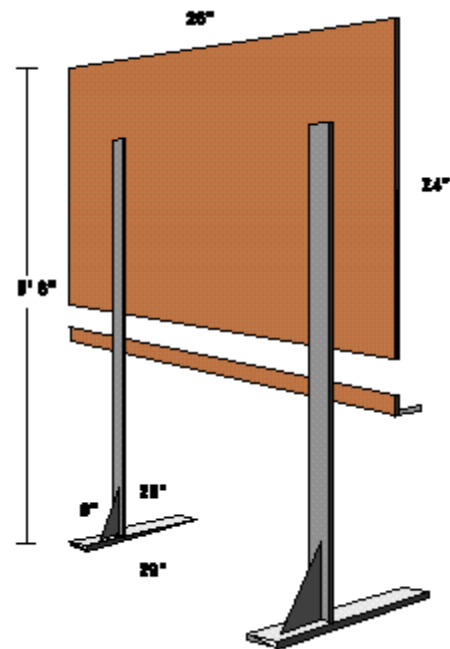

Vincent Practice Easel

This design was created by Wanda Cumings Vincent (3701 Bridlewood Cir., Stockton, CA 95629-2500) . Detailed plans are in her book, "Do it with chalk." It hangs from the ceiling and swings up and out of the way when not in use.

Parts:

Drawing board - 1/2" Plywood

Tray - 1" X 4"

Vertical supports - 1 X 3"s

Assembly:

Order her book, "Do it with chalk" for details.

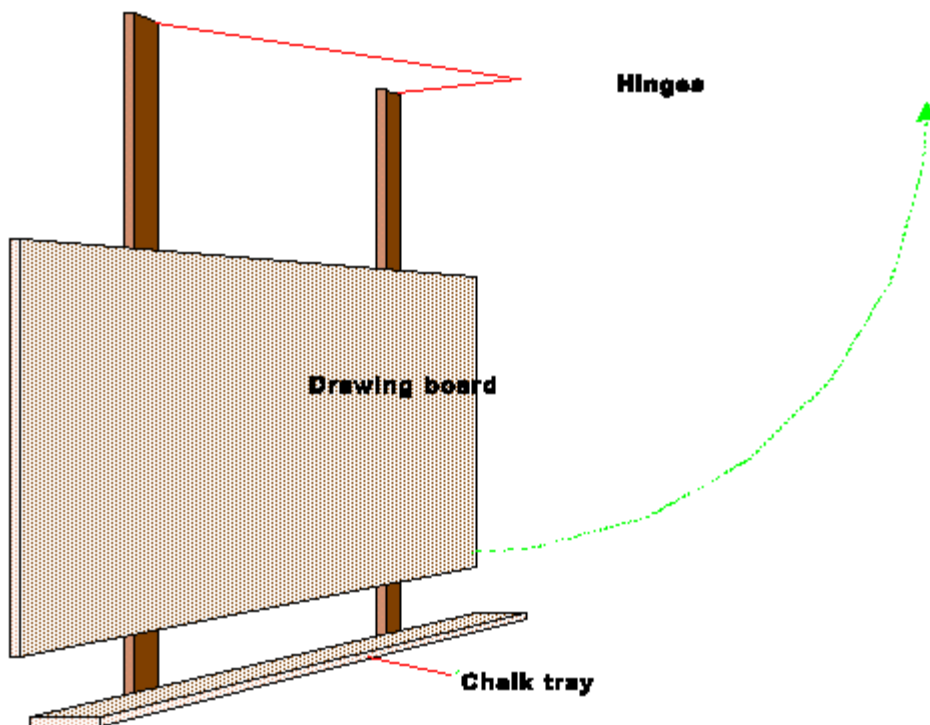

Tabletop Easels

To save space, weight and expense of transportation, some artists have designed table top easels which use a borrowed table at events to serve as easel legs.

Wooden Stand Alone Tabletop Easel

This easel is one piece and requires no on-sight setup. It's drawing board is the size of a half sheet of paper 24" x 40".

Parts

Wooden throughout with 1/4" drawing board.

Assembly

Wood screws. Chalk tray is the support stand



Grieger PVC Tabletop Easel

There are two sets of detachable feet designed to fit the two standard table sizes. It is lightweight, packs small and is adjustable. Black PVC looks best.

Parts

3/8" plywood
Black 1 1/2 PVC Pipe
PVC glue
PVC "T"s and angles

Assembly

Glue PVC connectors on one side only to allow Compact disassembly for transport.

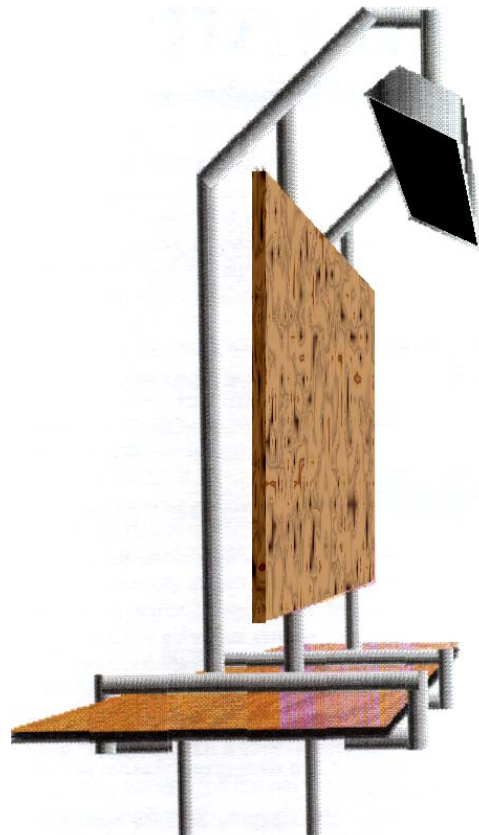

Tubular Tabletop Easel

This easel's drawing board folds in three places to form a box 15" X 15" X 40". It can be built to weigh less than 50 lbs. at a cost in materials of \$250 not including the light hood. It is as sturdy as the table it is placed on.

Parts:

Folding drawing board - 1/8" Plywood with a 1" X 3" support frame around each of its four panels (14 3/4" X 40"). Connect them with piano hinge on the backside.

1/2" Aluminum telescoping tubing (camera tripod legs)

36" adjustable bar clamp grips the table

Assembly:

1/4" bolts connect telescoping tubing for each bar but B

2" flat head bolts connect board to tubing.

Drawing board panels are joined with wood glue and 1/2" flat head screws.

Stiffen folding board with 1/2" C channel on the top and bottom of the board.

Light hood can be slotted for C or bolted on the outside into "T" nuts.

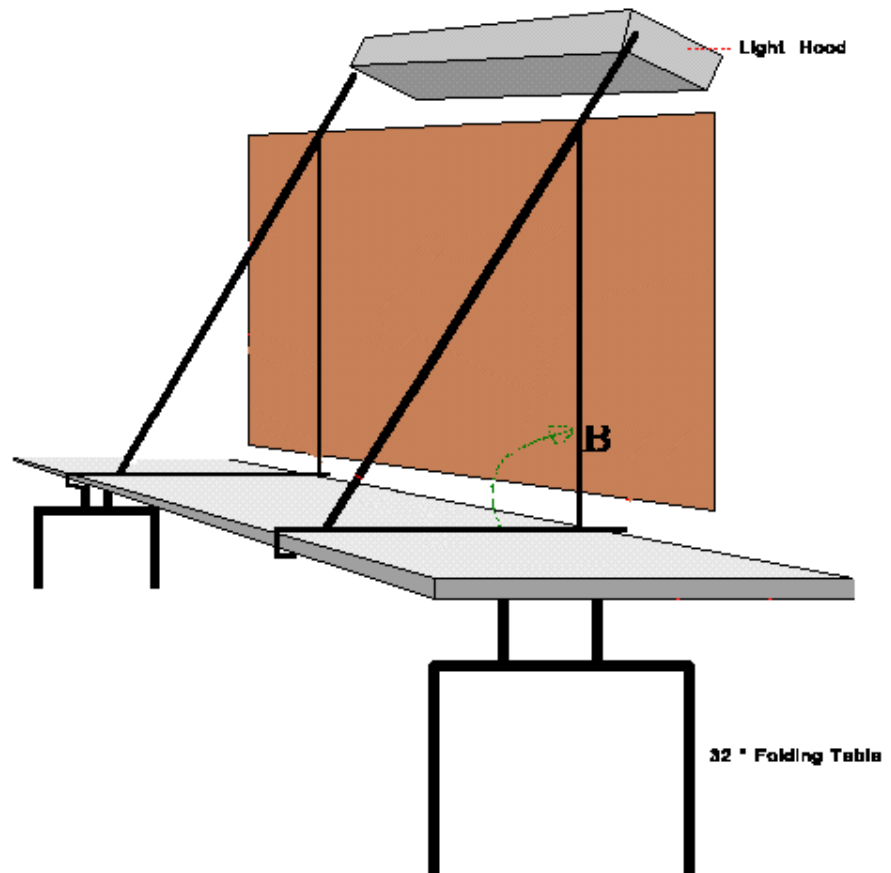

Portable Easels

General Suggestions

1. The distance from the last row of viewers will **determine board size**. Board size will determine your easel size. The finest bogus paper comes in 40" X 53" sheets. This size works well for churches where the viewers are less than 30 feet away.
2. Give at least 6" **clearance** between the bottom of the board and the chalk tray. This keeps sleeves out of the chalk while drawing the bottom of your picture.
3. Give at least 2" **clearance above** the head of the artist for the lighting system. Adjustable height is great when you have a low ceiling.
4. Your **lighting** should be from 18-24" from the board and evenly focused on the drawing surface. Be sure there are no obstructions so the light covers evenly without distracting shadows.
5. Keep the area where the artist stands **free of obstacles and hurdles** as in Figure 13a
6. Design your easel **sturdy**, so you don't have to draw on it 'as it goes by'. Vertical legs must be strong and heavy for stability. The easel must be able to handle the size of the board and the pressure of the artist's strokes without moving at all for accurate details. The easel in Figure 13b traded stability for portability.
7. People will judge your program by the **appearance** of your equipment. You never get a second chance to make a first impression. Keep everything neat, clean and attractive. Simple gear focuses attention on the drawing. Use a good drop cloth to catch all the dust.
8. Make equipment portable and rugged enough to transport with minimum wear and tear. New building materials are available. Cases, handles, dollies and castors can save hours of set up time in a years meetings. Drawing boards and frames can be made to fold and collapse. Legs can telescope, hinge, fold or be fit together with pins and sockets.

Figure 13a



Figure 13b

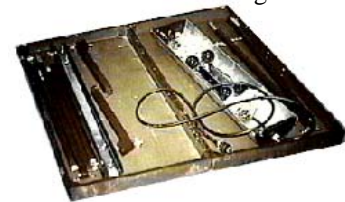

Easel design is usually a **trade off** between the following priorities:

- Cost
- Weight
- Size
- Stability
- Ease and speed of set up
- Obstacles (to trip over while drawing)
- Aesthetics (appearance)

Building materials

There are many types of materials used to build easels. The following chart is given to help rate possible choices. (good, fair, poor)

Material	Stability	Durability	Weight	Appearance	Economy
Wood	fair	poor	fair	fair	good
Aluminum	good	good	good	good	poor
PVC pipe	fair	fair	good	poor	fair

Sources for Aluminum Materials

Many products adapt well for easel design such as aircraft aluminum, ladder aluminum, larger TV camera tripods, heavy duty lighting stands, ultimate support speaker stands, curtain track and swimming pool cleaning poles. Scrap metal yards sell light aluminum tubing for as little as \$2 / pound! The illustration shows how to telescope and fold square tubing.

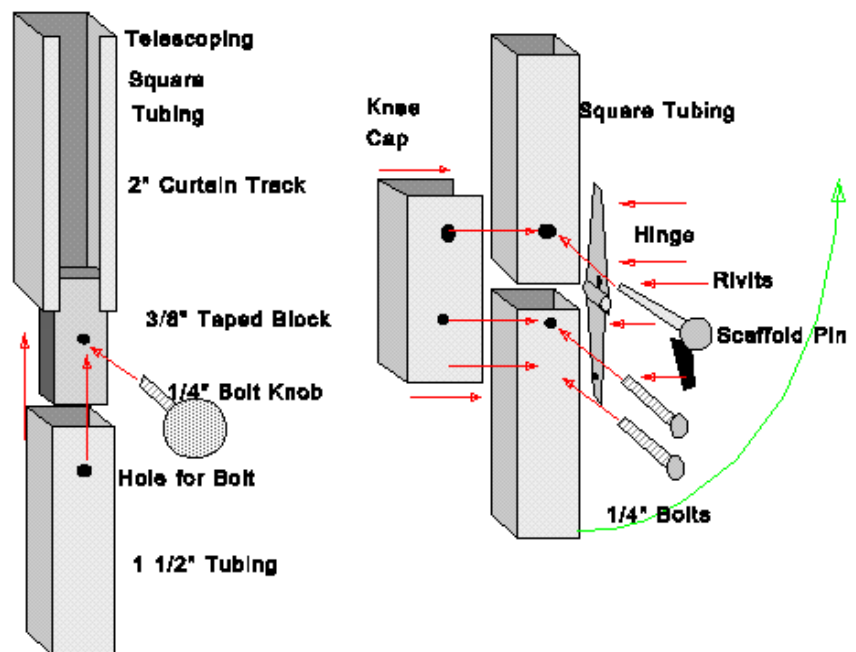

Britton Easel

This easel was designed by Everett Wayne Britton (858 Green Giant Road, Townsend, DE 19734). It is a very stable easel. It will work with a Plexiglas drawing board for rear projection. Its width can be expanded for larger drawing boards. The extra space between the drawing board and horizontal bars is for curtains hung above the two center vertical C supports.

Parts:

Drawing board - 1/2" to 3/4" Plywood covered with Formica
Legs - 1" Aluminum tubing
Tray - 1" X 4" wooden

Assembly:

1/4" bolts secure the A frames and rear braces.
Everything else fits together with bayonet mounts.
(posts and sockets)
The light bar has a slot which slides over two 1/4" aluminum flanges.
The center vertical poles hang with finger hooks on the

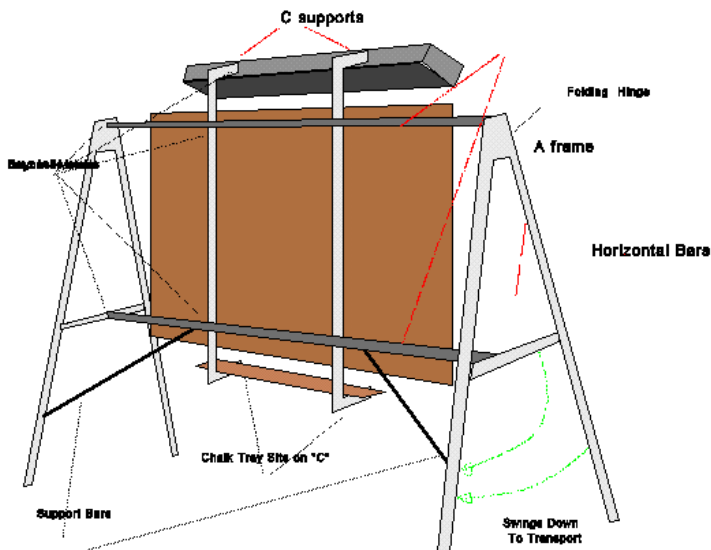

Fielden Easel

Parts:

Drawing board and rear slots- 40" X 53" Wooden 1/2" plywood

Chalk tray - 1" X 4" wooden

Legs -1/2" Stainless steel welded into one solid piece

Light hood - stainless steel

Assembly:

Everything else fits together with bayonet mounts into the rear drawing board slots.

The light hood has two built in sockets for the removable supports.

The light hood wire travels through one of the support bars.

Chalk tray sits on leg assembly.

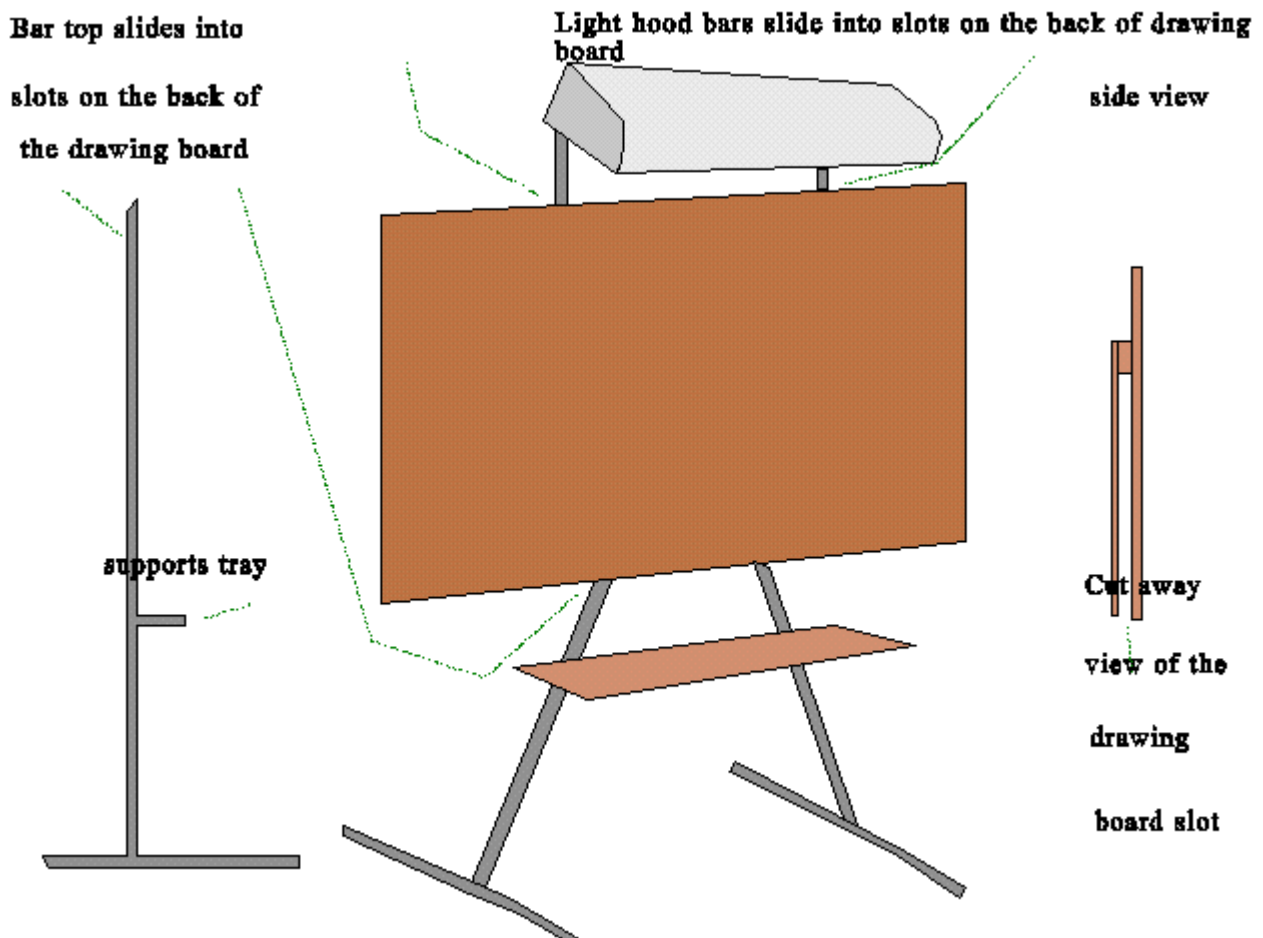

Flip - over Easel

Parts:

Drawing board - 1/2" plywood box

Chalk tray - none to allow the drawing board to rotate 360 degrees

Legs - 1/3" wooden

Light hood - wooden

Assembly:

Easel legs are a folding A with scaffold pin to lock the backside of the A

The drawing is mounted on a lazy Susan roller bearing

The light hood hangs on lever action rocker arm held in the rear by chains

The light hood raises to allow the drawing board to pivot upside down



Forsythe Easel

Parts:

All metal frame

Drawing board: 36" X 46"

Assembly:

Order complete easel and light system from Don Forsythe.

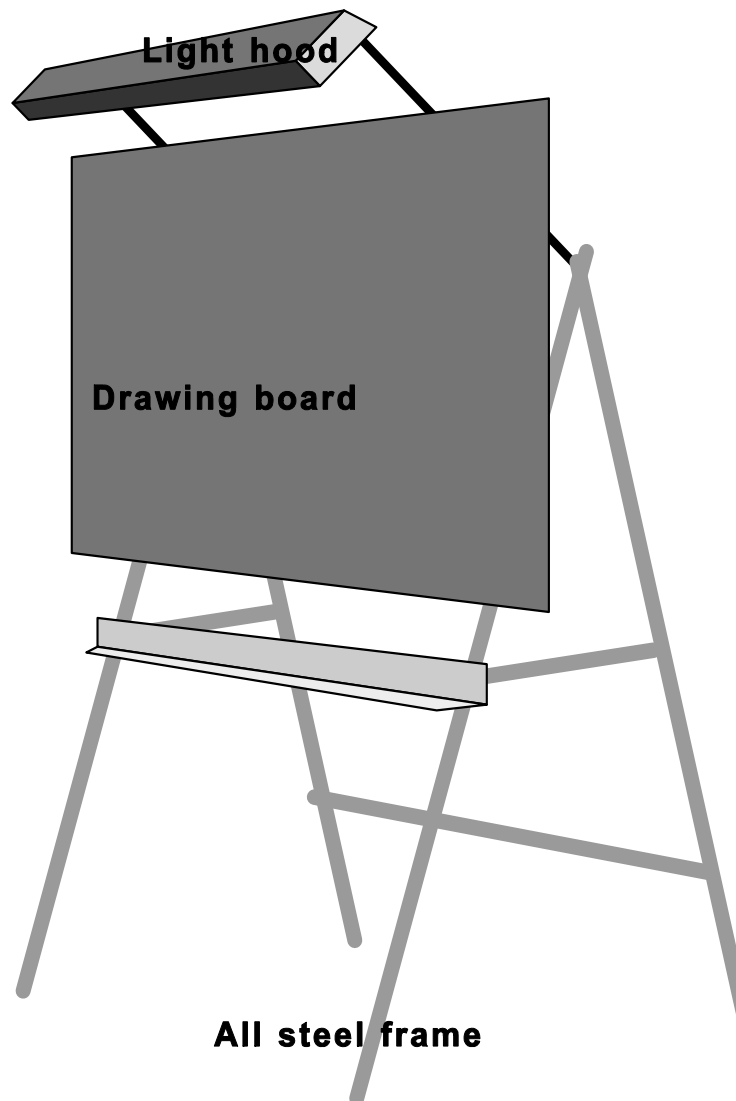

Glenn Tripod Easel

Ben has designed a unique tripod of extension tubing. It is joined (above) with three support clamps bolted together. His drawing and colored lights are mounted above.

Parts:

DJ Stand Support Extension bars
DJ Stand Support Connectors



Grieger Easel

Parts:

Drawing board, light hood and light hood supports: aluminum

Legs: RV chrome plated 2 1/2" table legs

Base: Plywood box to hold everything but the drawing board

Assembly:

RV legs insert into RV leg receptacles on the top of box

Tray and legs fit into box channel brace on the back of the drawing board

Light hood and its support slide into the top of the same box channel

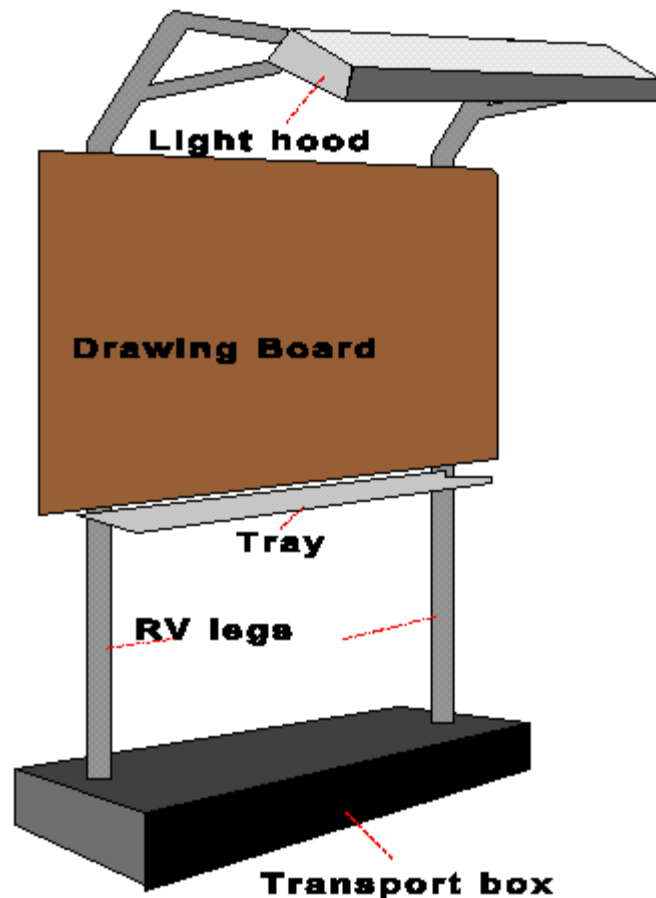

Layne Animated Easel

Parts:

- Drawing board - 1/4" Plexiglas
- Chalk tray - 1" X 4" aluminum
- Legs - 1/2" telescoping aluminum
- Light hood - aluminum

Assembly:

- Easel base is a tripod folding aluminum table
- Triangular wings fold off of table with piano hinge to support drawing board
- The light hood hangs on removable supports held by wing nuts
- The light hood wire travels through one of the support bars.
- Chalk tray sits on leg assembly
- Add side curtains to hide rear projectors if necessary

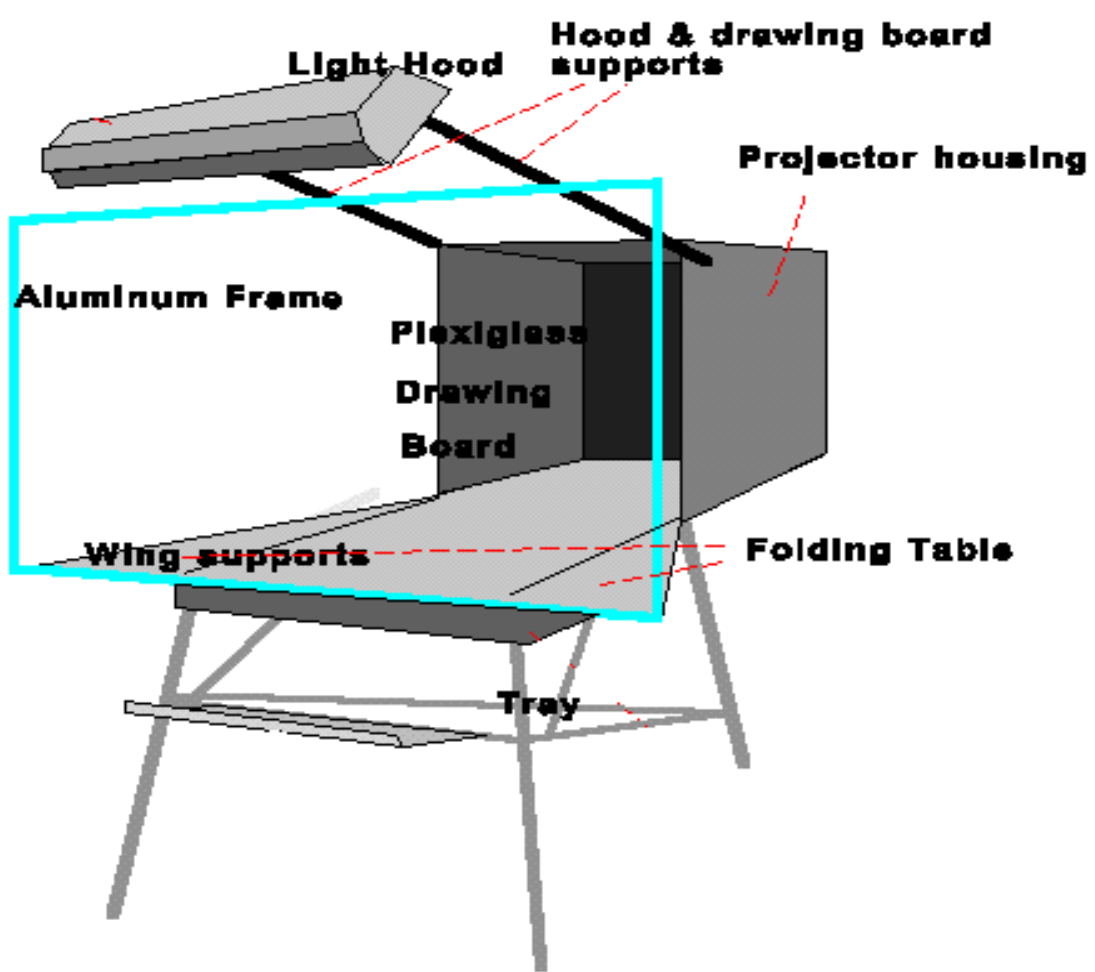

Melin Easel

A well crafted wooden easel by Jonathan M Melin at jimchalk2@juno.com



Oak Easel

Parts:

Drawing board - 1/2" plywood

Chalk tray - 1" X 4" oak

Legs - 1" X 2" oak

Light hood - oak with
aluminum lining

Assembly:

Legs are one piece dowel
pinned and glued oak

Braces, tray & light hood
attached with screws

Drawing board is hung with a mirror hanger

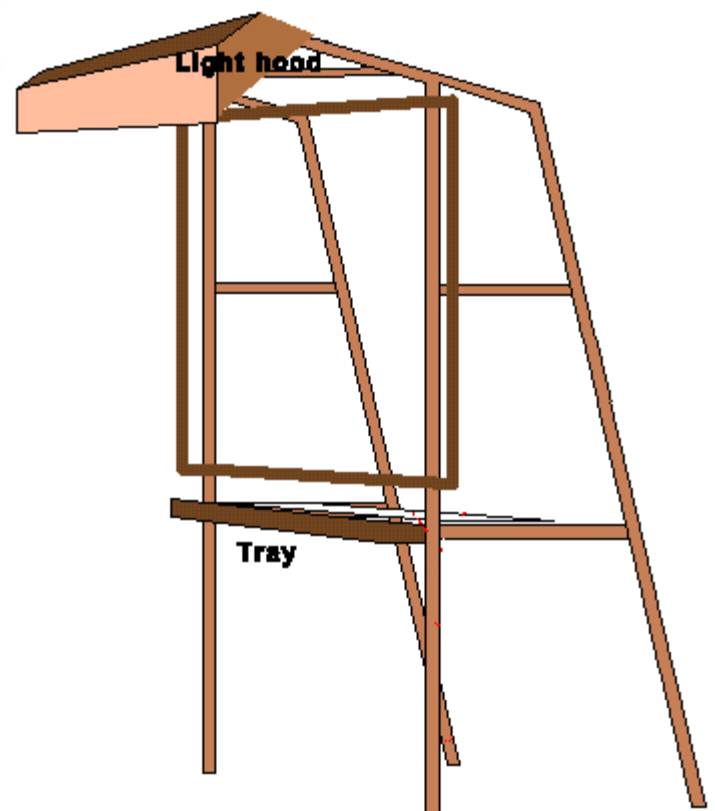
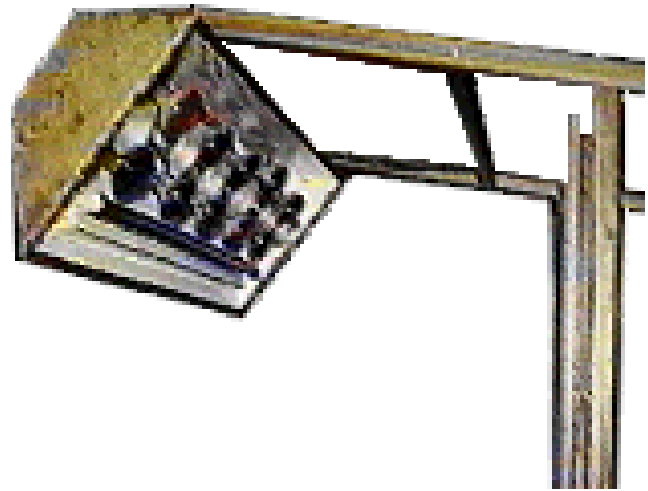

Tripod Portable Easel

This sturdy, ultra-light easel has fully adjustable leveling from 4 foot to 7 feet tall, white, red, blue, black light and strobe lights, rugged light bar, control box with easy to find bulbs, and compact, 4-way foldable drawing board panels. The entire easel, light bar, control box, drawing board, 6 sheets of paper and chalk fit in one rolling golf bag for air travel.

Q Part Description

- 3 1 1/2 inch Aluminum legs
- 2 3/4 inch Aluminum legs
- 2 1/2 inch Aluminum legs
- 4 1/4 inch reinforced wooden panels
- 1 Wood, piano hinge, hardware
- 2 40 inch metal square tubing
- 3 Rubber Feet
- 1 Turn buckle

Function

- Main Legs – 3 telescoping
- Rear braces – 2 telescoping
- Front braces – 3 telescoping
- Drawing boards
- Chalk Tray
- Light bar / board mounts
- Tripod feet
- Light hood angle adjustment

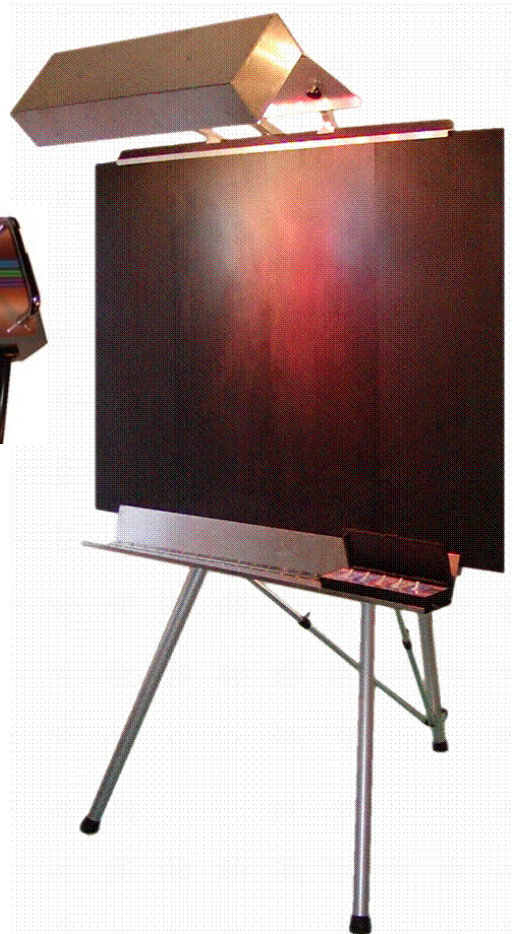

Rear View



Parts of the Tripod

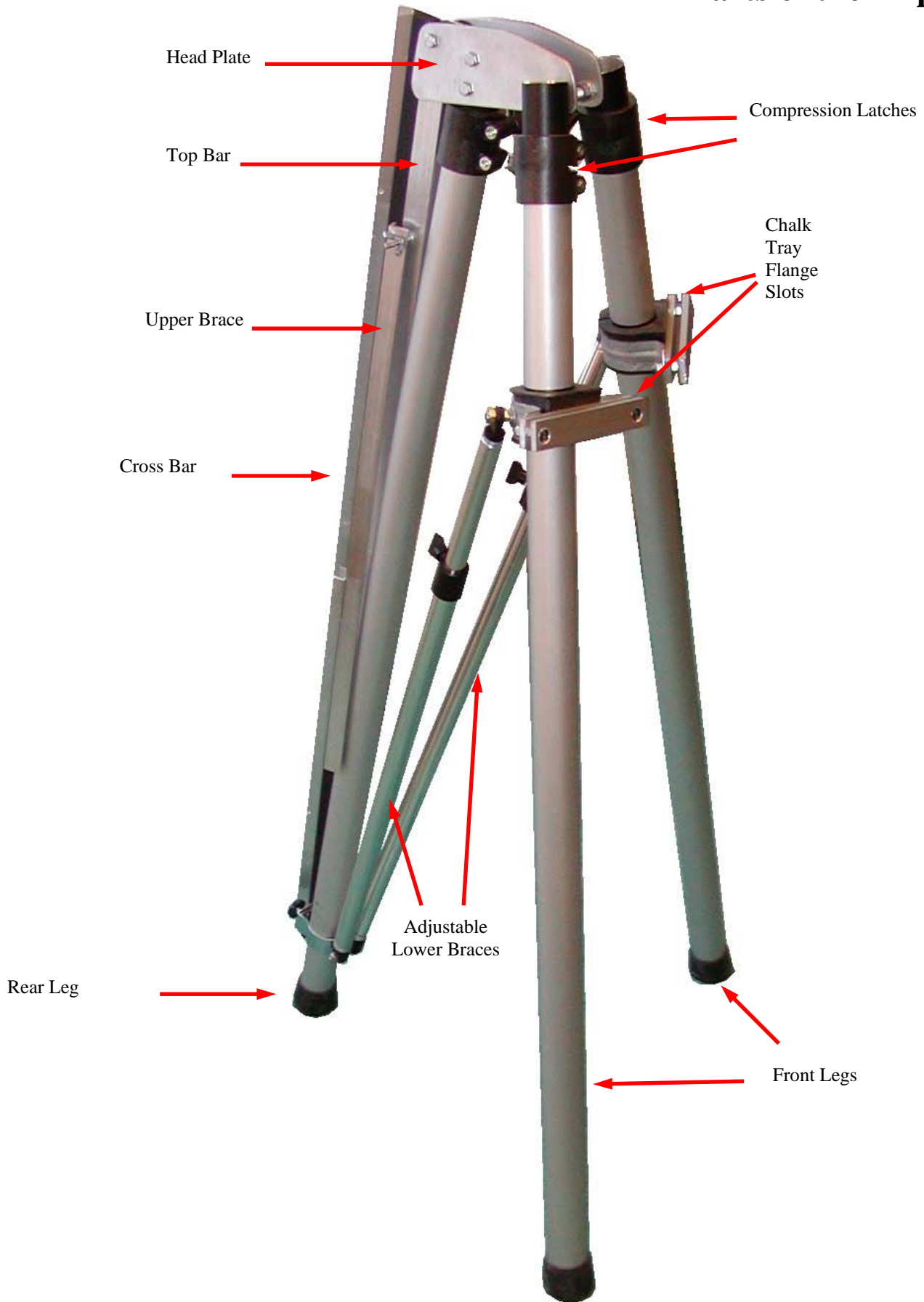

The Light Hood

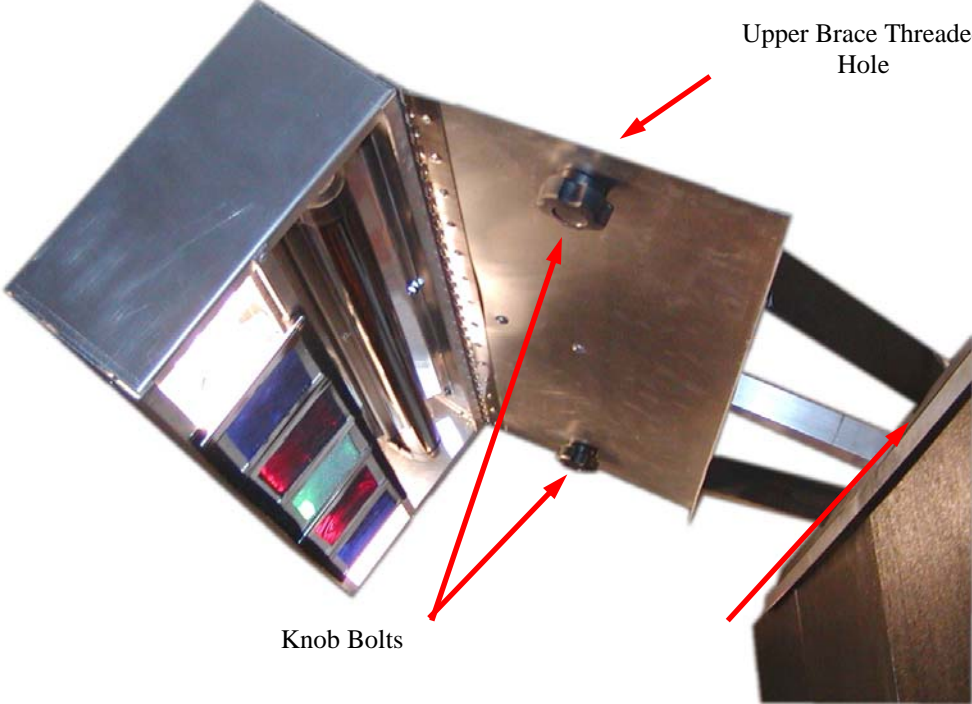
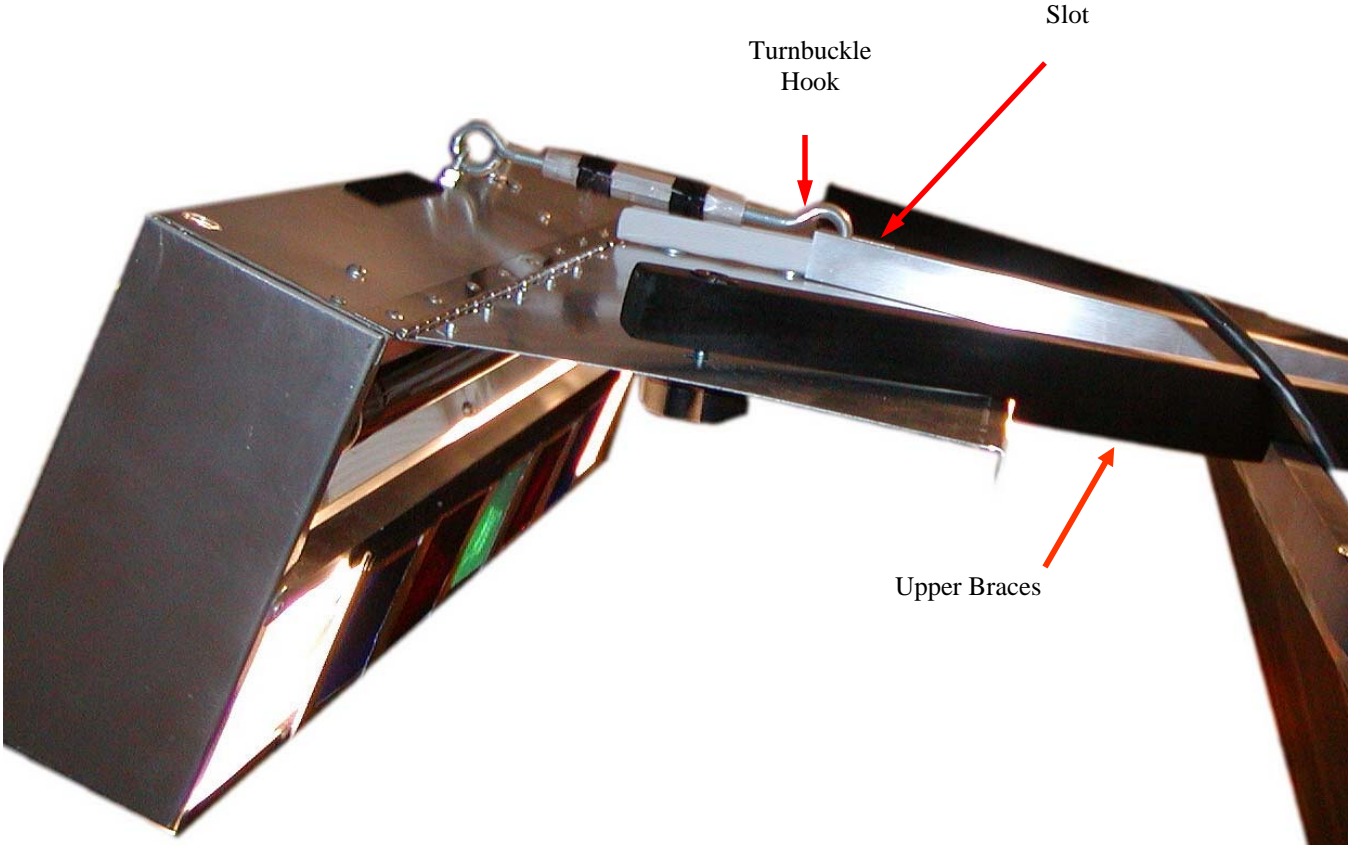

Light Hood Assembly

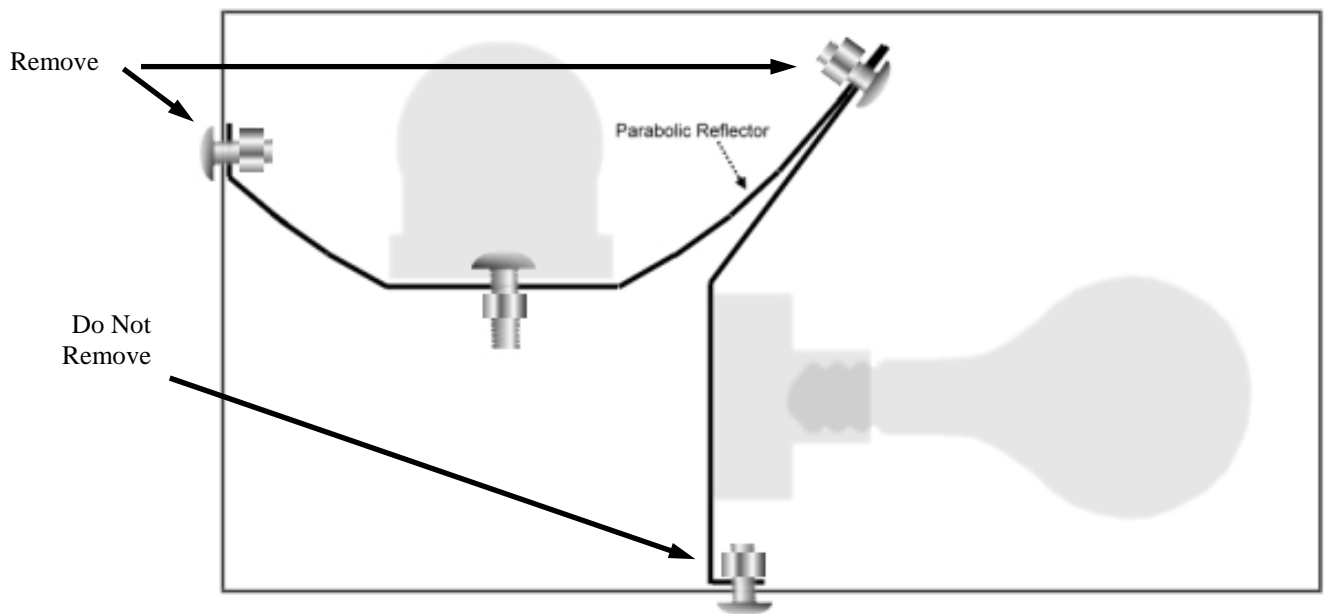

Read Easel

This design was created by Tom Reed. The legs fold to 3' for transport. It is surprisingly sturdy for its size and weight. Full-or half size easel, light weight wooden, 10 minute set-up, control for dimming lights, legs fold with knee locks. Custom designed and maintained to your needs. Low cost and free financing.



Parts:

Drawing board - 1/2" to 3/4" Plywood
Legs - 2" X 2" Wooden, or 1" Aluminum tubing

Assembly:

1/4" bolts for tripod plate and top "C" channel swivel arm
1" flat head screws for C Channel mounts to 1" X 4" wooden chalk tray
1" flat head screws for C Channel mounts to 1" X 2" top swivel arm



Slagle Easel

Parts:

Drawing board - 1/2" plywood box
Chalk tray - 1" X 4" aluminum
Legs - 1/2" peg and socket aluminum
Light hood - aluminum

Assembly:

Easel legs are a folding A with a ladder hinge
All parts fit inside drawing board box for easy transport
The light hood hangs on removable supports held by wing nuts
The light hood wire travels through one of the support bars.
Chalk tray hangs off the bottom of the box assembly.

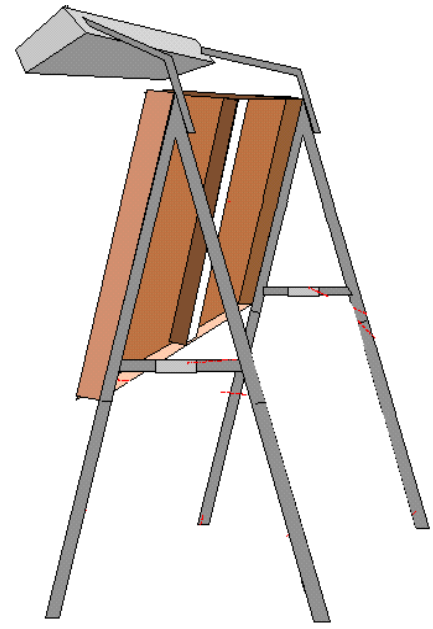

Smith Easel

Parts:

Drawing board - 40" X 53" Wooden 1/2" plywood

Chalk tray - 1" X 4" 1/32" aluminum

Legs - 1" tubular aluminum

Light hood - aluminum or galvanized metal

Assembly:

Legs fit together with pins and sockets

The light hood has 2 built in sockets for the removable supports.

The light hood wire travels through one of the support bars.

Chalk tray mounts to board

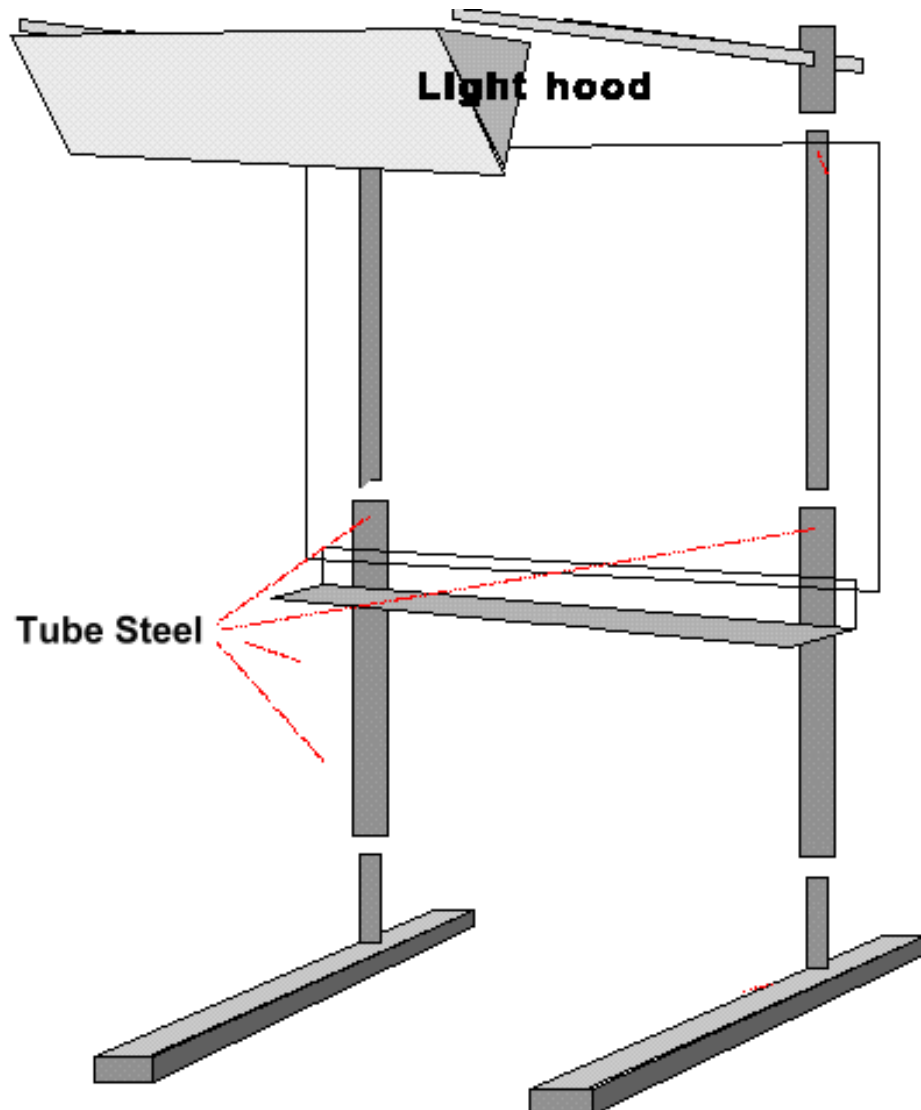

Teuling Easel

This easel was designed and sold by Ding and Dave Teuling. Their board folds in half. The parts fit in well designed light weight cases. Full-size easel, using a 40" x 54" sheet of paper with moderate weight and rapid set-up, a professional appearance, compact hand control for dimming lights, tubular steel legs (chromed) and polished aluminum feet. Two carrying cases are included for legs and lights. Easel folds to half-size. David LeGrand manufactures and sells easels based on this design. You may order his easel by calling David at 336-725-2041

Parts:

Drawing board - 1/32" aluminum reinforced with aluminum box channel

Legs - 2 1/2" Stainless steel recreational vehicle legs

Feet - Polished aluminum with recreational vehicle Receptacles

Light hood, chalk tray and curved supports - stainless steel

Assembly:

Everything else fits together with bayonet mounts. (posts and sockets)

The light hood has 2 built in sockets for the removable curved supports.

The light hood wire travels through one of the curved support bars.

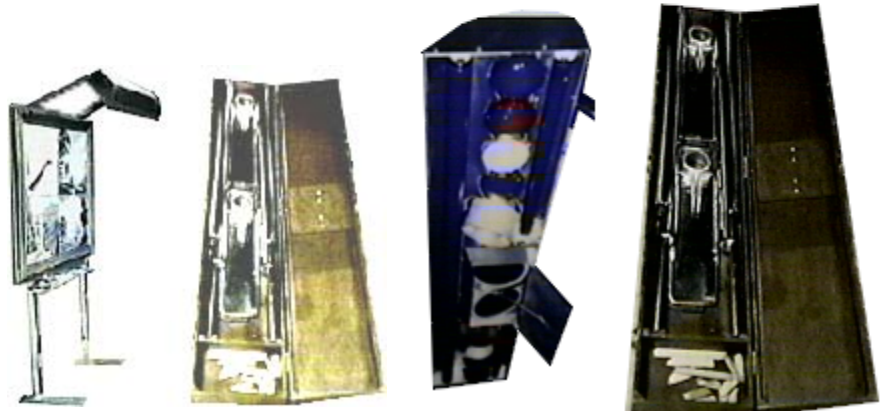
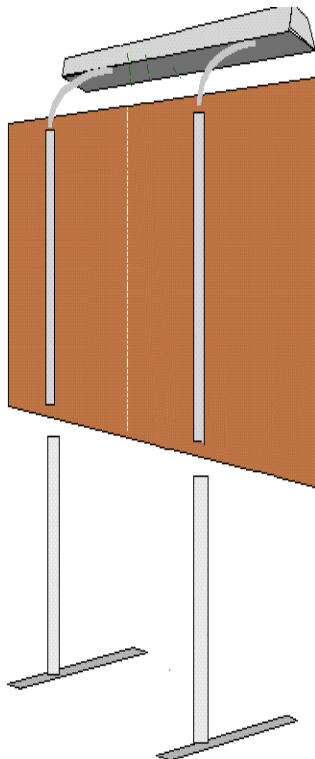

Turnpike Easel

This design is used for portable signs along the new Jersey Turnpike. Pull two pins and the whole easel folds flat!

Parts:

Drawing board - 40" X 53" Wooden 1/2" plywood

Chalk tray - 1" X 4" wooden or aluminum

Legs - 1 - 1/2" aluminum thin wall Square tubing or I beam

Center frame - 1 1/2" thick wall aluminum L

Light hood - stainless steel



Assembly:

The center light blue square is welded together into one solid piece.

The top and back bars are bolted with 1/4" pivot bolts.

The lower front legs are pinned to support the center light blue square frame.

The light hood support bars slide into the vertical support bars

The light hood wire travels through one of the support bars.

Chalk tray hangs on the light blue cross bar.

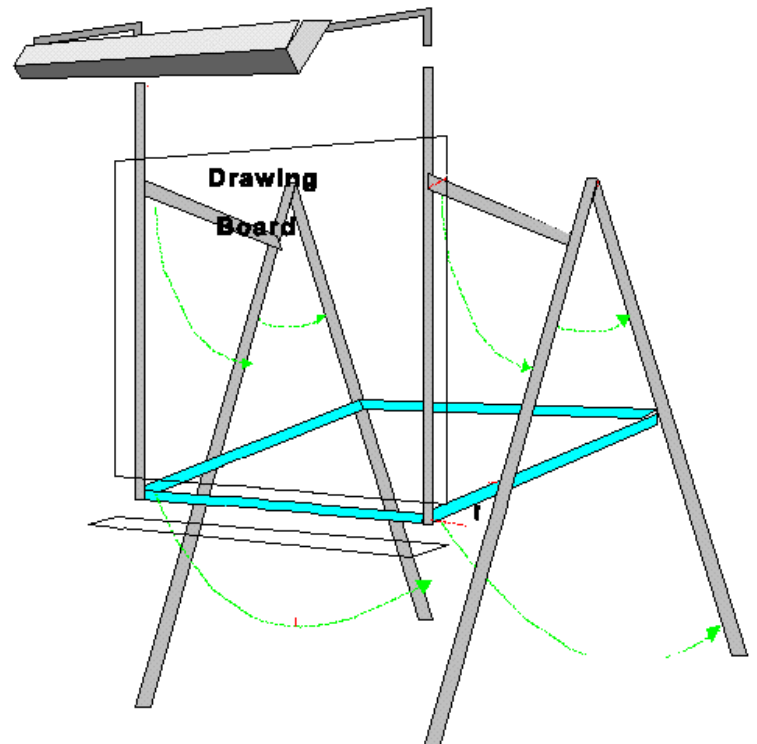

Vincent Easel

(Detailed plans may be ordered from Wanda Vincent (3701 Bridlewood Cir., Stockton, CA 95629-2500))

Parts:

Folding Drawing board - 40" X 53", 1/2" aircraft aluminum with piano hinge

Chalk tray - 1" X 4" aluminum

Legs - 1" and 1/2" tubular aircraft aluminum

Feet - 1" X 4" Iron C channel on casters

Light hood - 1/16" aluminum

Assembly:

Everything else slides together with pins and sockets

The light hood has 2 built in sockets for the support pins.

Chalk tray sits on leg assembly.

Legs slide together with pins and sockets

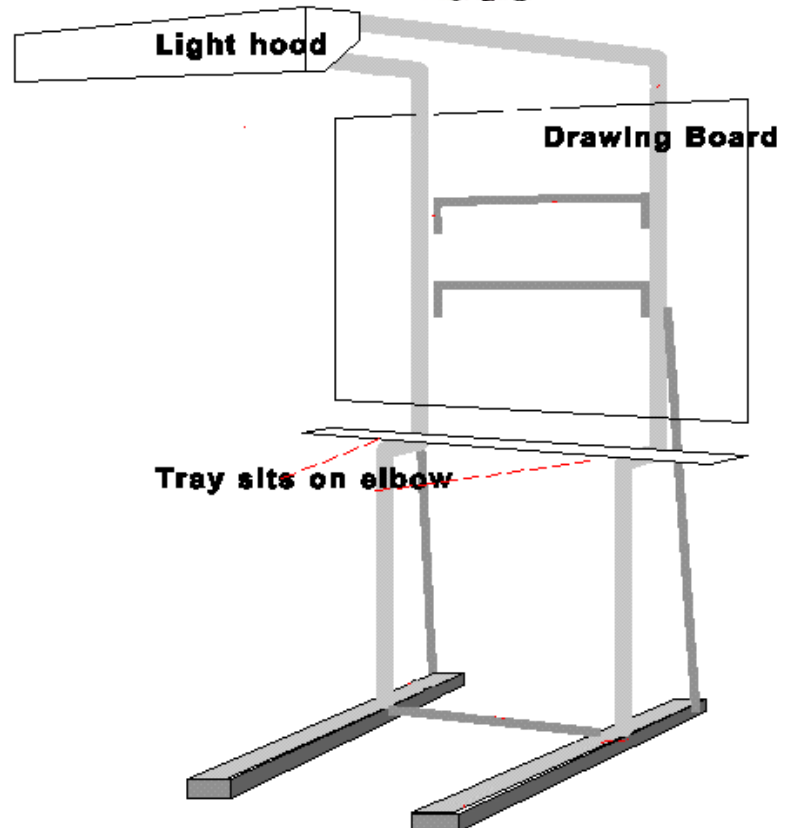

Zwall Easel

Parts:

Drawing board - 1/2" plywood box
Chalk tray - 1" X 4" aluminum
Legs - 1/2" peg and socket aluminum
Light hood - aluminum

Assembly:

Easel legs are a folding A with a ladder hinge
All parts fit inside drawing board box for easy transport
The light hood hangs on removable supports held by wing nuts
The light hood wire travels through one of the support bars.
Chalk tray hangs off the bottom of the box assembly.

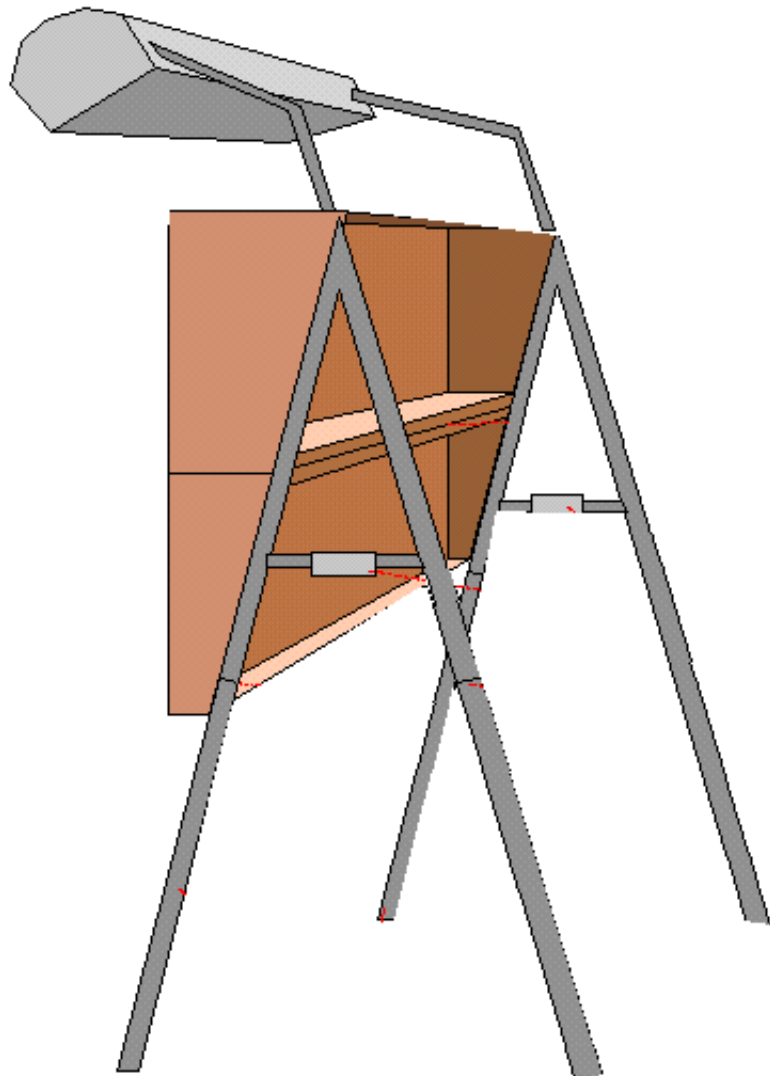

Heavy Duty Temporary Bed Sheet Easel

This easel designed to be built on site for an event and left behind (discarded) after an event.

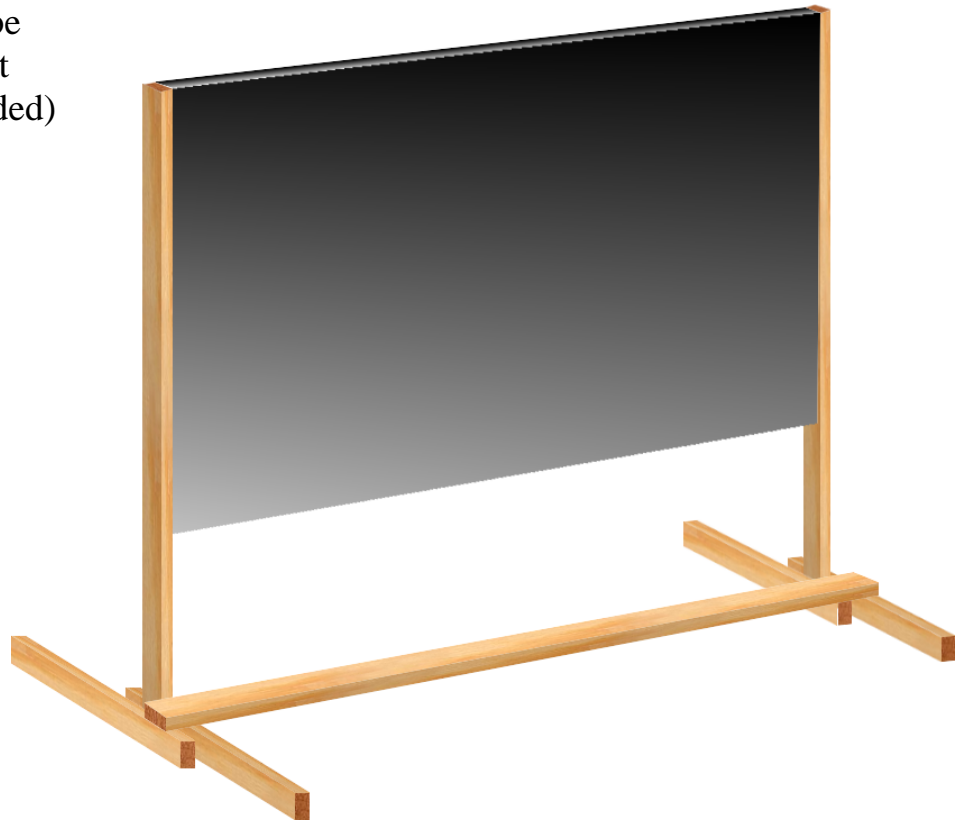

Quantity	Tools and Parts Needed for the Easel	Supplier
1	Staple Gun with about 100 staples that are at least 1/2 inch long	Home Depot
50	2 1/4 or 2 1/2 inch long decking screws	Home Depot
1	Drill Screw Driver with head bit designed for the decking screws	Home Depot
8	8 foot 2x3's lumber (2 inches by 3 inches)	Home Depot
2	Flat black or blue bed sheets – queen size	Wal-Mart

Step 1: Assemble the Frame as Shown Below

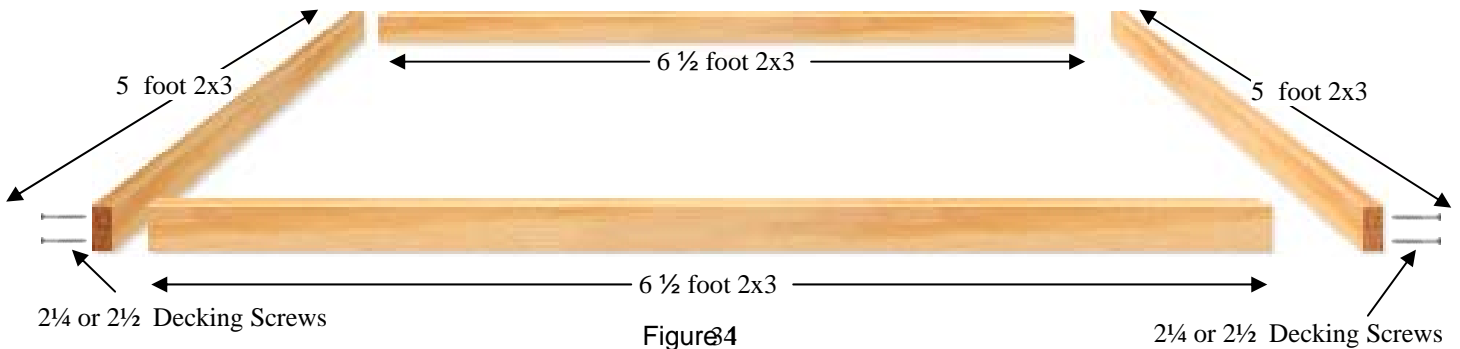

Step 2: Stretch and Staple the Bed Sheets into a Tight Canvas

Wrap both sheets tightly around the frame together and staple them to the frame with as much tension as possible. (Figure 2) If done correctly, you should be able to bounce a coin off of them. Pull hard to remove wrinkles and slack as you go. Don't worry if the sheets sound like they are going to rip. To work properly as a canvas, the sheets should be stretched as tight as a drum, with be no flex in them.

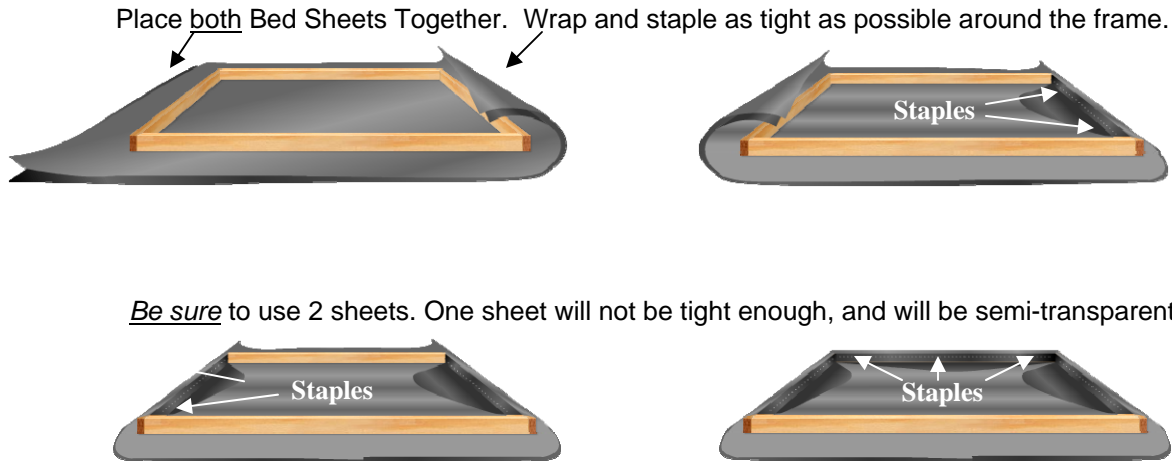
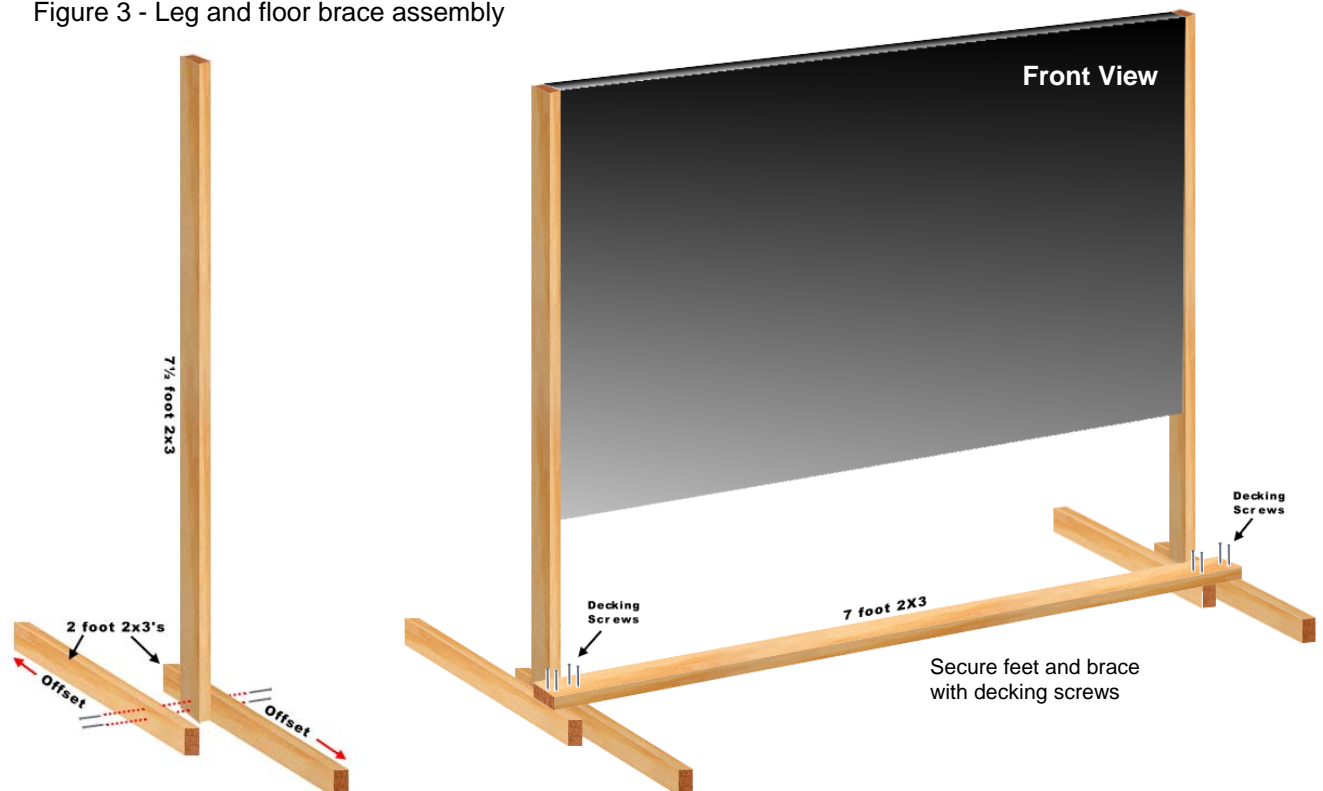

Figure 2 - Making the bed sheet canvas

Step 3: Leg and Brace Assembly

Cut one 8 foot 2x3 into 4 equal pieces, each 2 feet long. Take these 2 foot 2x3s and secure one on each side of the 7½ foot board at the bottom to act as legs. (Figure 3) Offset each of these 'feet' so they widen the base. Use about 2 to 3 decking screws to make sure that they are secure. Transport the easel to the event location, before attaching the legs and brace with decking screws. Then, lay the final 8 foot 2x3 across on the bottom to act as a brace and secure with the decking screws.

Figure 3 - Leg and floor brace assembly



Light Weight Temporary Bed Sheet Easel

This easel designed to be built on site for an event and left behind (discarded) after an event.

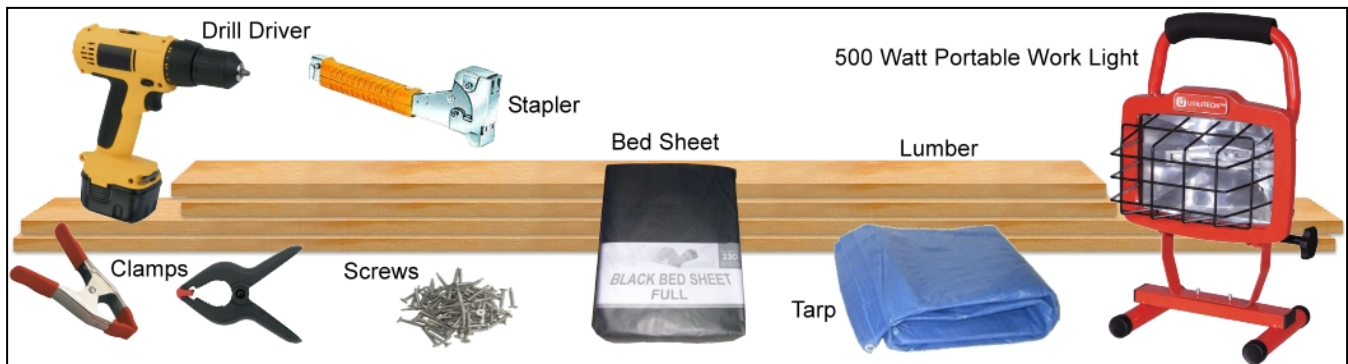
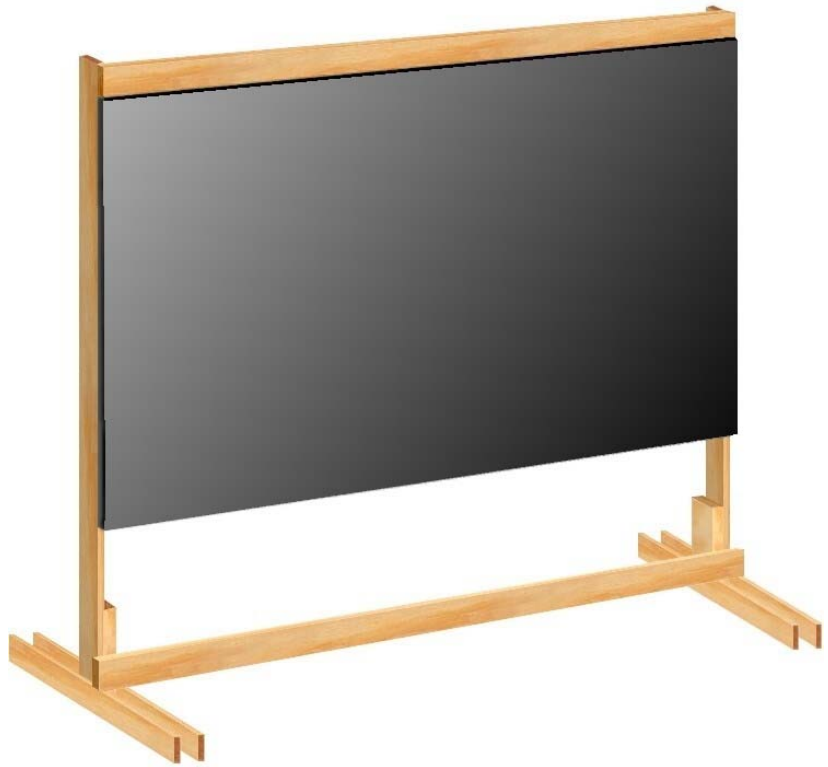

Quantity	Size	Description
2	7 foot	1x4 pine boards
6	6 foot	1x4 pine boards
4	2 foot	1x4 pine boards
2	1 foot	2x4 pine boards
50	1 ¼ inch	deck or drywall screws
1	500 watt	Portable Work Light
6	2 inch	Spring Clamps
1	Roll	Duct Tape
1	9x12 foot	General Purpose Tarp

Bed Sheet Easel Stretch Frame

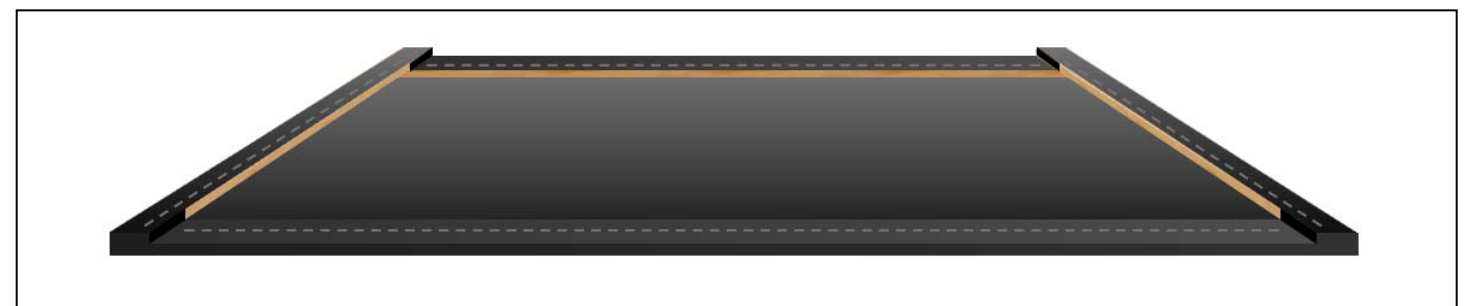
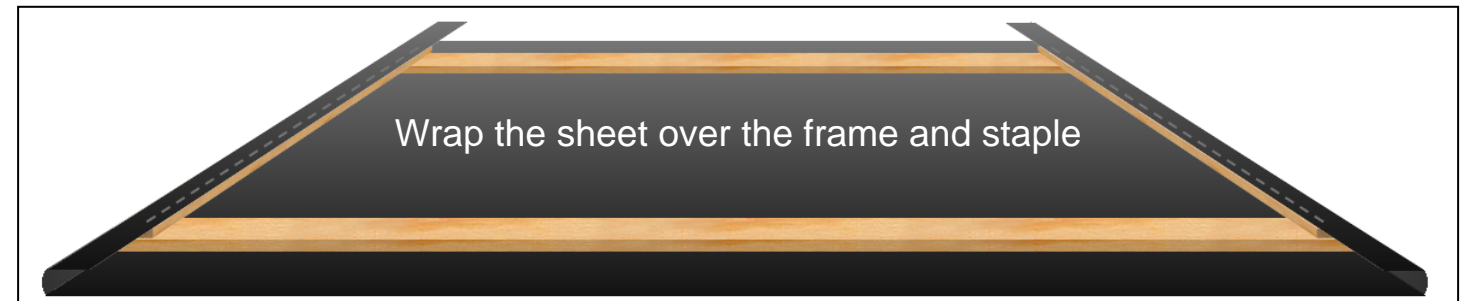
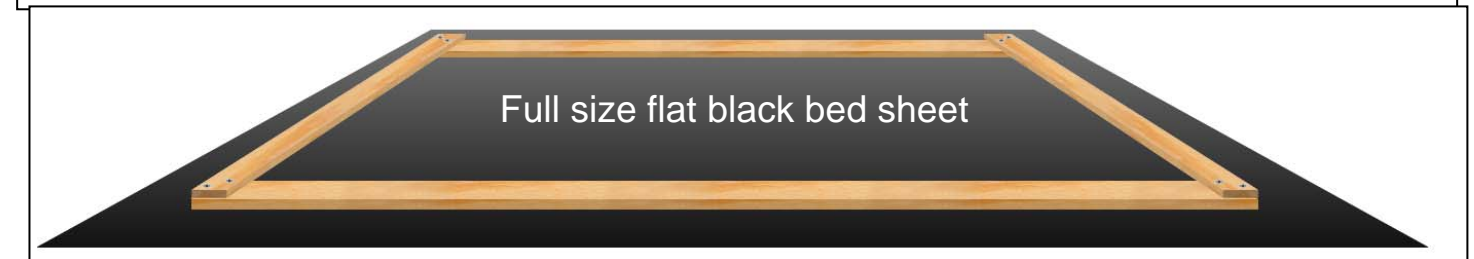
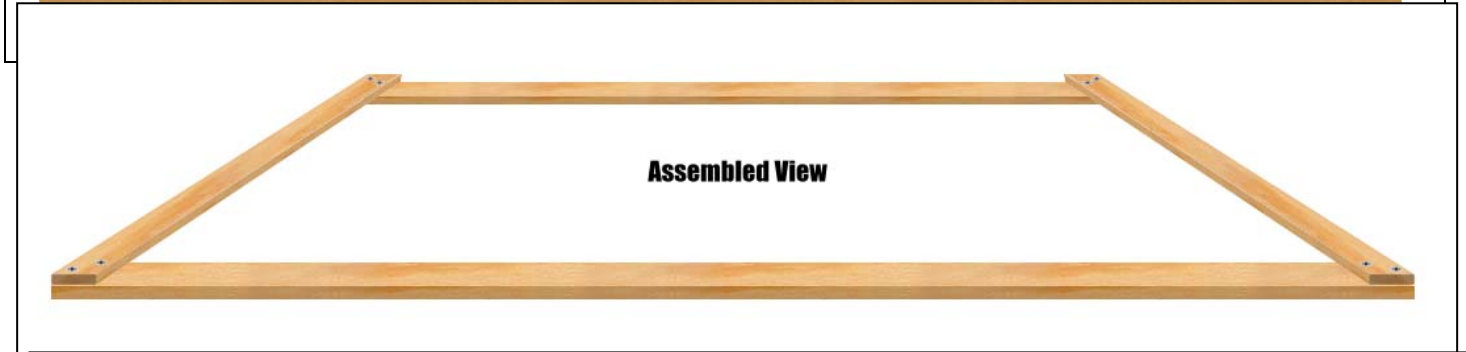
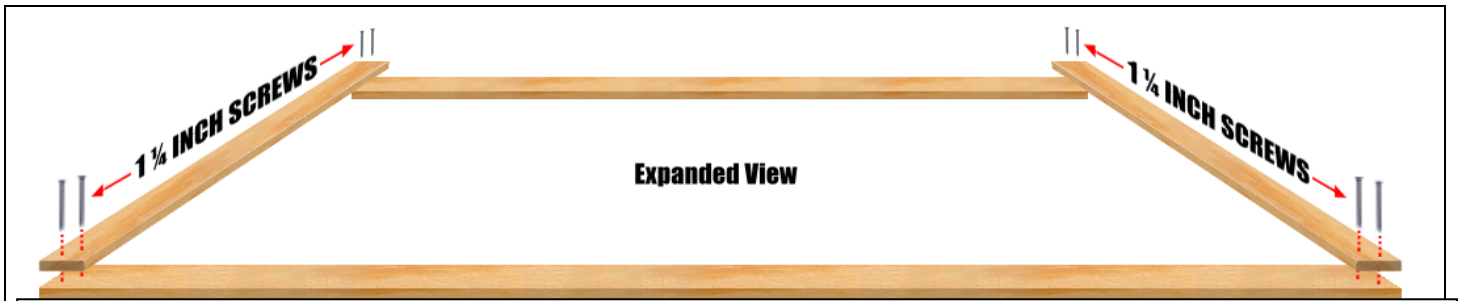

Large Format Easels

Live cameras with video projection can assist viewing of small drawing boards for large groups. However, one special service featured a drawing 48 feet wide and 5 feet tall, drawn by 16 artists, for a 4000 seat auditorium.

How large should your board be? The *ideal* drawing board width according to the industry standard (the Society of Motion Picture and Television Engineers) should be larger than the distance to the last row of seats divided by six.

- A board 24 feet from the last row should be at least 4 feet wide.
- A board 30 feet from the last row should be at least 5 feet wide.
- A board 36 feet from the last row should be at least 6 feet wide.
- A board 42 feet from the last row should be at least 7 feet wide.
- A board 48 feet from the last row should be at least 8 feet wide.
- A board 54 feet from the last row should be at least 9 feet wide.
- A board 60 feet from the last row should be at least 10 feet wide.
- A board 120 feet from the last row should be at least 20 feet wide.

For large buildings, where the last viewer is over 35 feet away, tape two or more sheets of bogus paper together with wide masking tape. For distances greater than 60 feet stretched canvas or large bed sheet material is best.

It is possible to make your board too large to be viewed properly. Those closest will see the picture skewed, panned or keystone out of proportion. Screen width should not exceed one half the distance from the first row.

- A board 4 feet from the first row should be no larger than 2 feet wide.
- A board 8 feet from the first row should be no larger than 4 feet wide.
- A board 10 feet from the first row should be no larger than 5 feet wide.
- A board 12 feet from the first row should be no larger than 6 feet wide.
- A board 14 feet from the first row should be no larger than 7 feet wide.
- A board 16 feet from the first row should be no larger than 8 feet wide.
- A board 18 feet from the first row should be no larger than 9 feet wide.
- A board 20 feet from the first row should be no larger than 10 feet wide.

Large format drawing requires a much stronger easel. This means more bulk and weight to haul. It will take longer to set up and tear down. The drawing must be more carefully planned to appear correct. A few portable easels already described can be extended to handle large format.

Da-lite Fast - Fold Easel

Parts:

Many sizes and shapes of portable projection screen frames work well using stretched fabric as a drawing surface.

Purchase the legs and frame from Da-Lite Screen Company.



Assembly:

Mount canvas tarp snaps to material so the frame will stretch it tight enough to draw on.

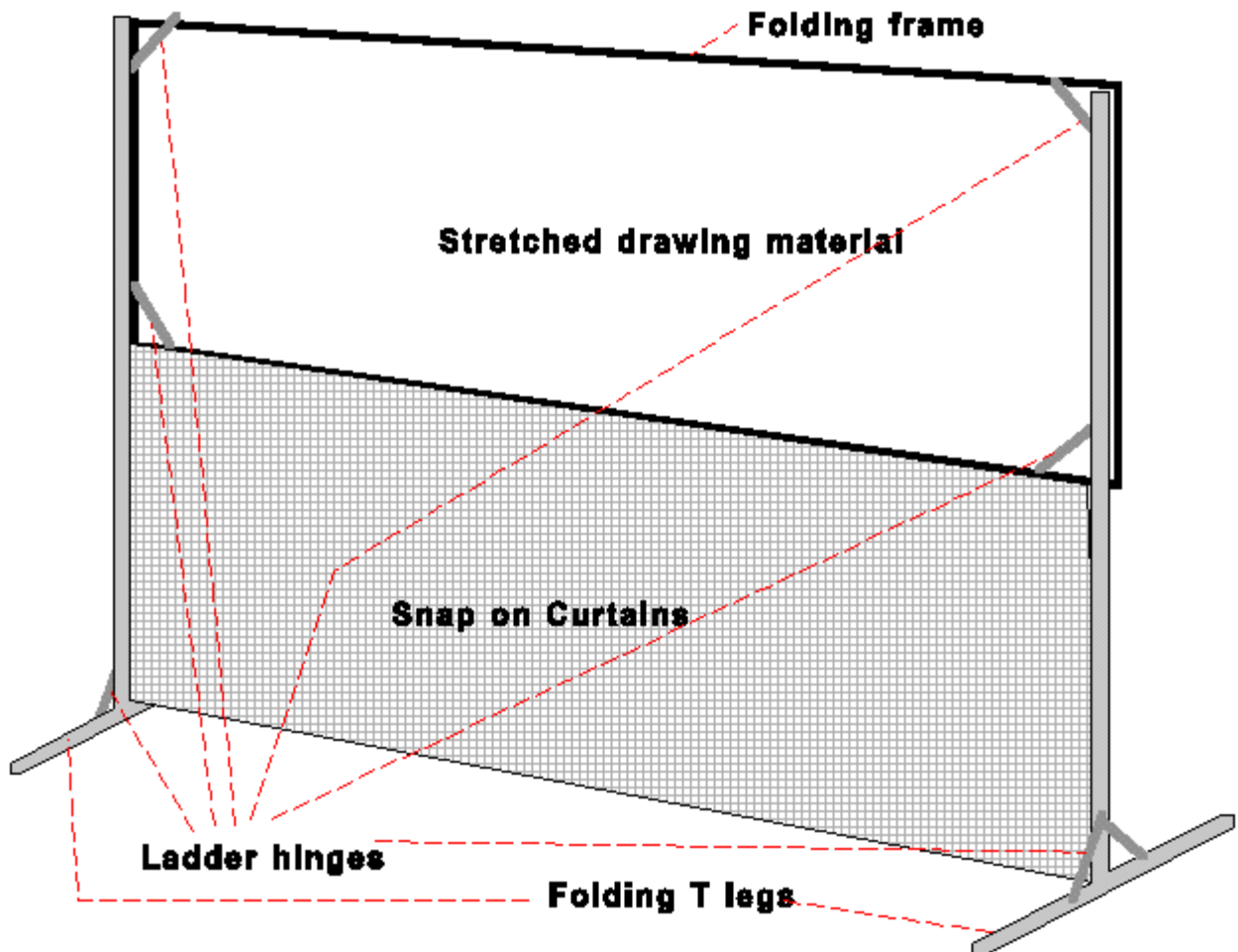

Dual Tripod Easel

Those who carry sound systems with sturdy speaker stands may wish to adopt this easel design. It will work well with larger drawing surfaces. **Remember to aim speakers away from live microphones.** Light duty tripods may not be able to support the weight of a drawing board and lighting system.

Parts:

Many sizes and shapes of portable projection screen frames work well using stretched fabric as a drawing surface.

Purchase the frame from Da-Lite Screen Company, Warsaw, IN 46580 (219) 267-8101 or build it from 1" thin wall square tubing.

Assembly:

Mount canvas tarp snaps to material so the frame will stretch it tight enough to draw on.

Attach frame to speaker stands with 1/4" bolts and wing nuts or use 1/4" riveted T nuts with thumb screws.

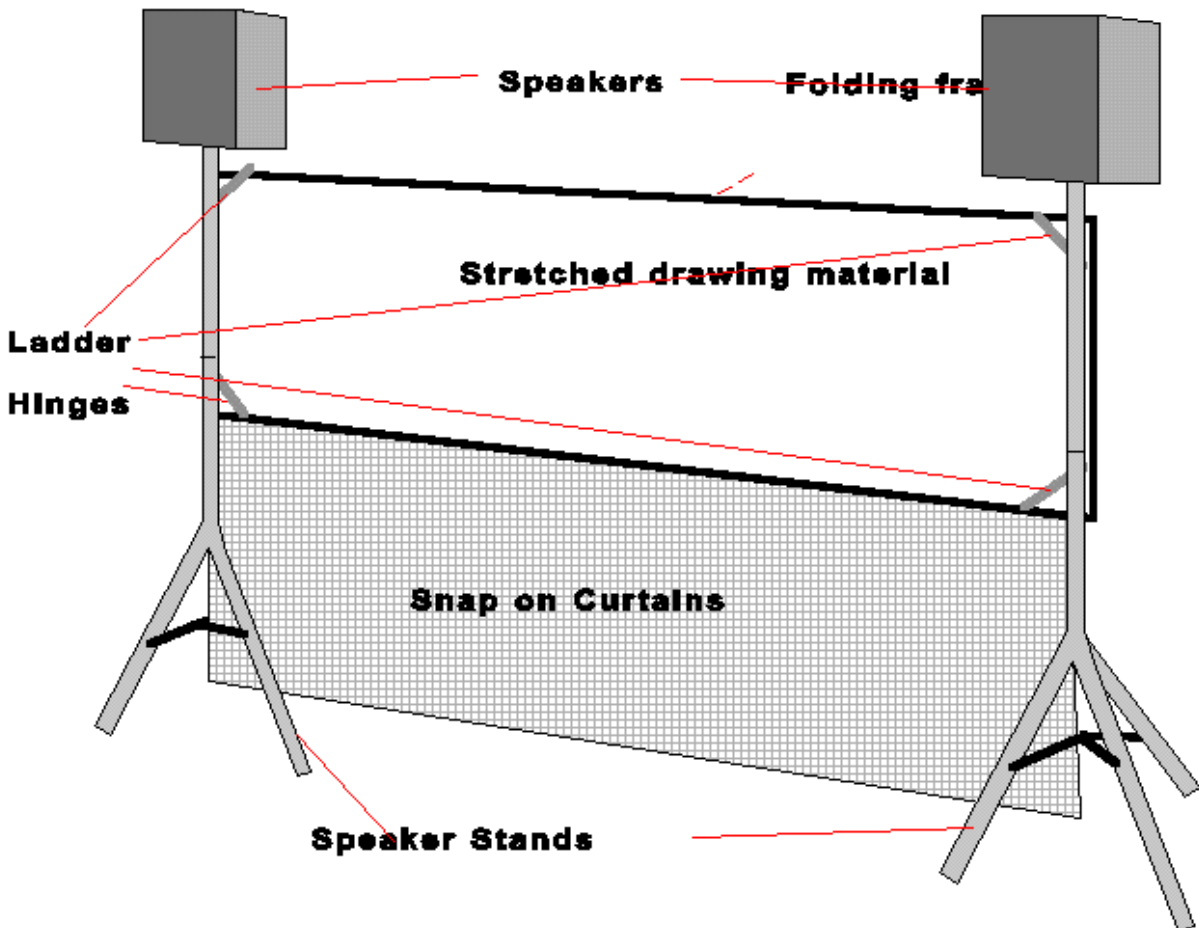

Rear Projection Easel

This was used by Bill Leach for extensive rear projection and 'see through the board effects.

Parts:

Portable exhibition displays are available from professional conventions.

Three set frames - 1" aluminum tubing, 2 1/2" PVC pipe or 2" X 2" wood

Braces - 1/2" tubular aluminum bolted to set frame

Front curtain and board hanger - aluminum braced frame

Assembly:

The sets are fit together with pins and sockets or braced securely

The sets pin together with loose pin hinges

The drawing board and tray hang on the center set braces

The lights are either rear projected through the drawing or from side lights.

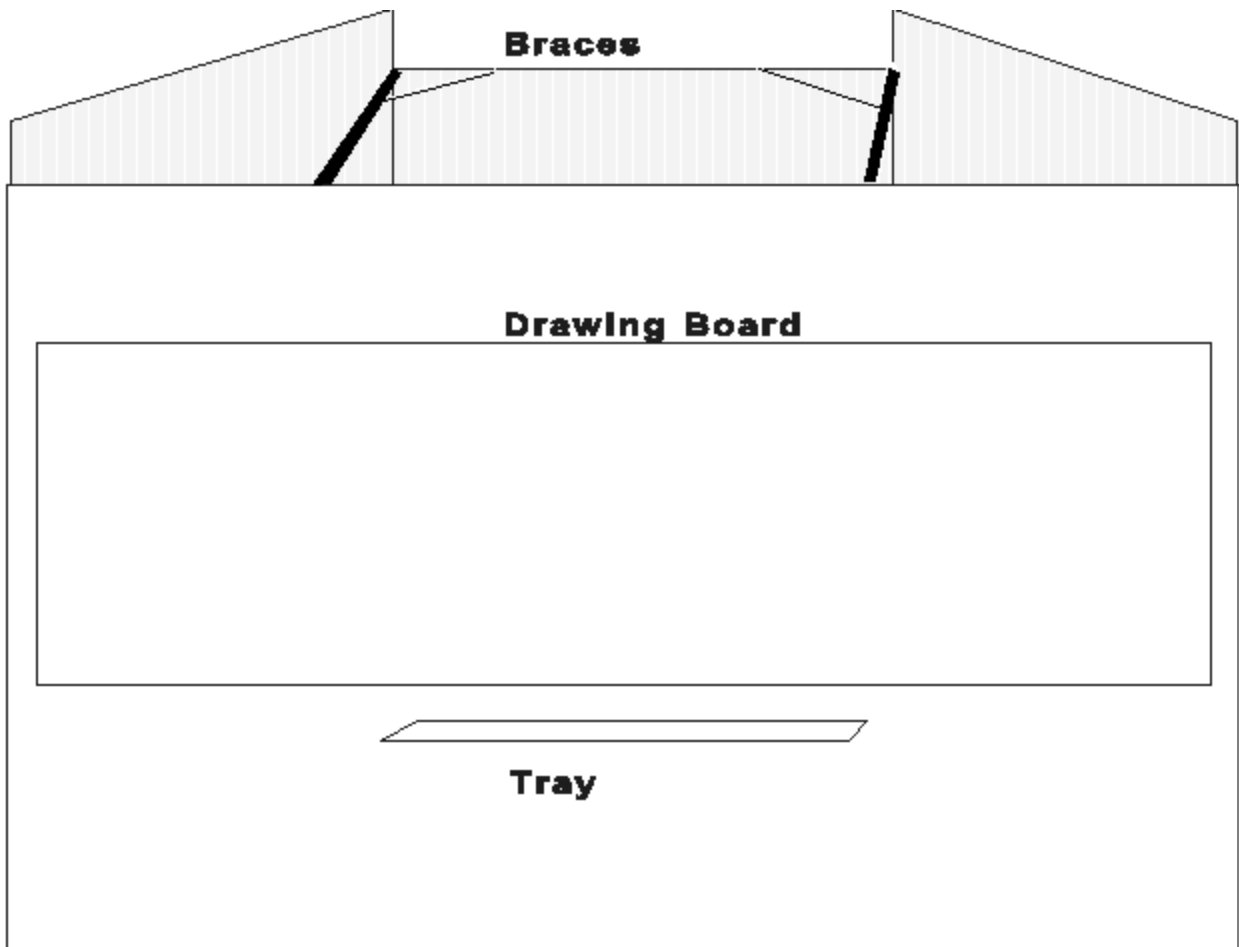

Stage Easel

Parts:

Portable exhibition displays are available from professional conventions.

Three set frames - 1" aluminum tubing, 2 1/2" PVC pipe or 2" X 2" wood

Braces - 1/2" tubular aluminum bolted to set frame and tri - beam

Front curtain and light hangar - aluminum antenna tri - beam

Assembly:

The sets are fit together with pins and sockets or braced securely

The sets pin together with loose pin hinges

The drawing board and tray hang on the center set braces

The lights hang from the center tri - beam

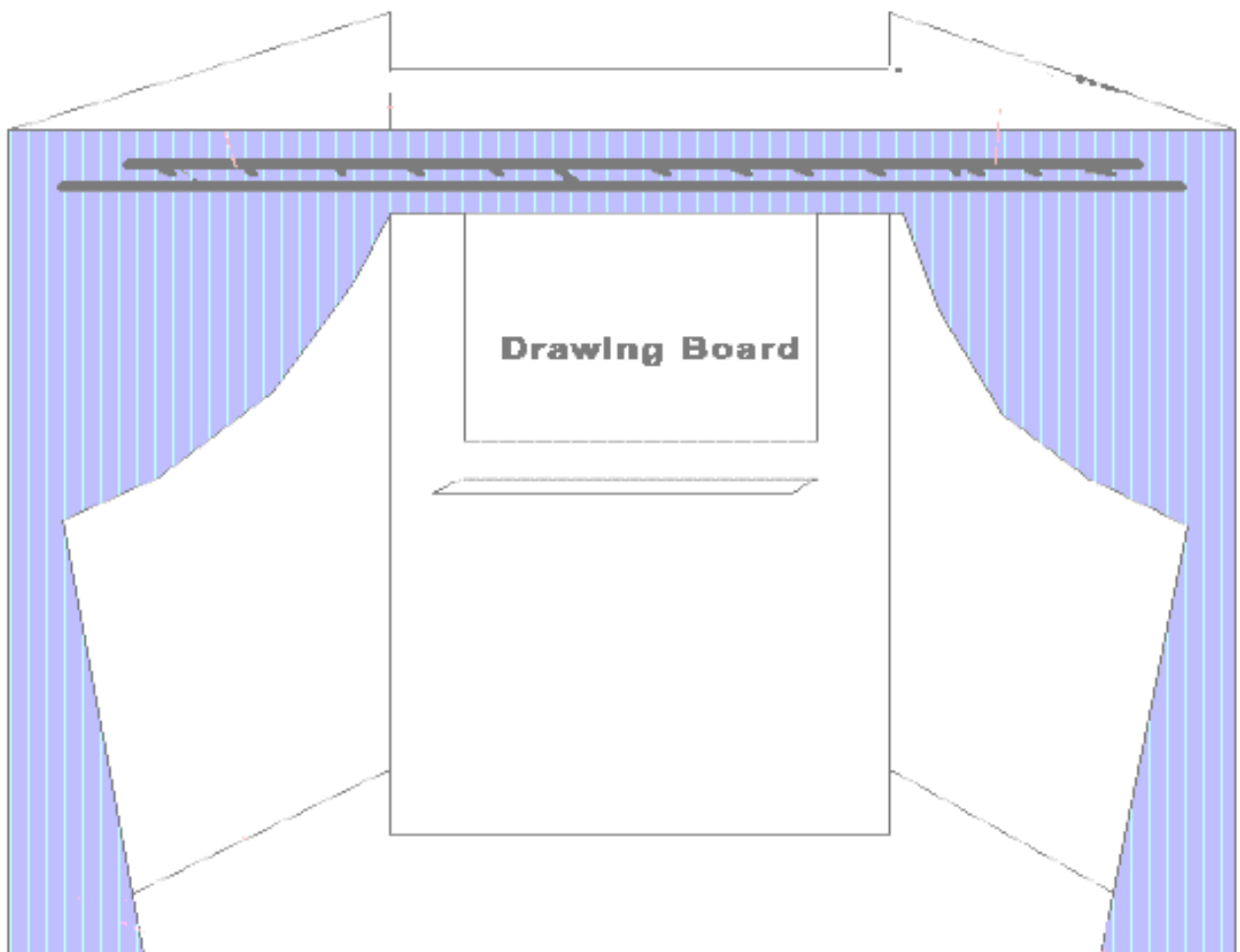

Tharp Easel

Parts:

13' Plexiglas Drawing board folds out with curtains on back to hide picture

Wooden Tray and light hood Stabilize board fold outs

Legs and feet - 3" thick wall welded aluminum

Assembly:

Legs bayonet mount

Loose pin hinges

foldouts

Tray and hood - tongue
in groove

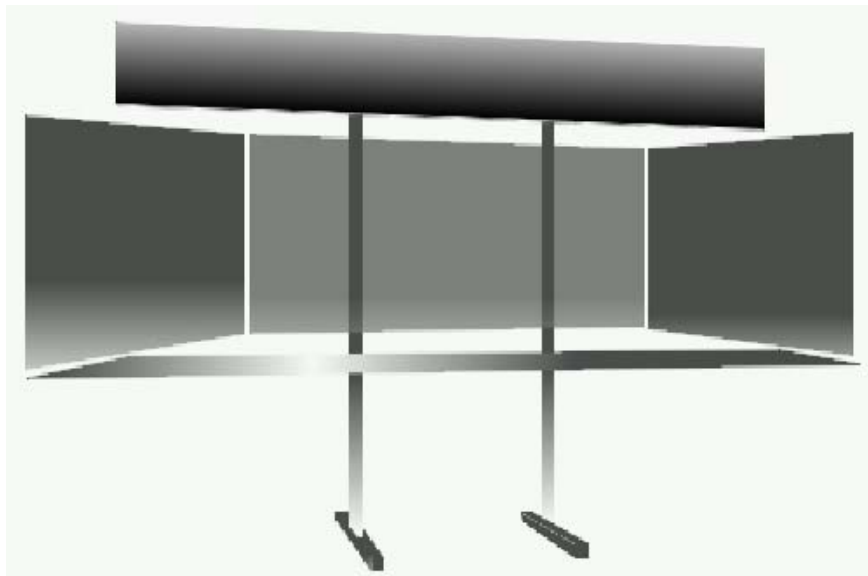

BASIC LIGHTING



Drawing Lights

Balanced lighting will enhance your drawing's color accuracy, and overall impact. Unbalanced lighting will change colors and make realism difficult. Florescent lighting does not work well for drawing lights. It produces too much light toward the purple end of the spectrum. That's why skin looks green under it. Incandescent lighting leans toward the yellow end of the spectrum. That's why skin looks orange under it. Unbalanced lighting can make some colors of chalk practically indistinguishable. Also, light that is too bright closes the eye's iris. This limits color reception and makes color 'wash out' like an over exposed picture.

Most artists find the best affordable balanced lighting: 2 *soft white* incandescent 60 to 150 watt light bulbs, suspended approximately 18" - 24" away from your picture. Soft White bulbs are color corrected for the incandescent yellowing with a slight blue tint. LED lighting works well, but it can be more expensive.

Colored Lights for Dramatic Effects

Most artists fade in red and blue colored lights using dimmer switches. These two colors throw the picture's values into dramatic contrast. Under red light: red chalk washes out with oranges and yellows, while blue chalk appears more black. Under blue light: red chalk darkens toward purple and blue chalk tints to appear more like white.

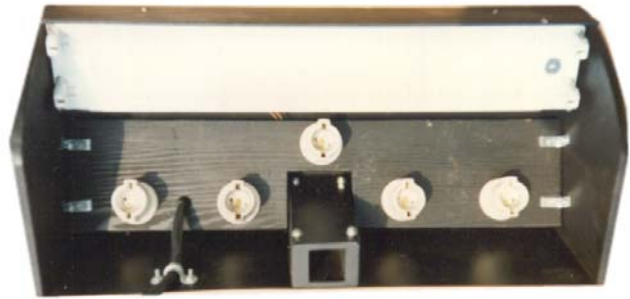

Figure 36 Examples of how colored light can effect a picture

Some artists use amber lights for a pastel color softening effect. Green lights are not usually used because of their unpleasant effect on most pictures (See Above). Spotlights are sometimes used to highlight subjects or delay revealing of hidden black light pictures since UV light requires a more expensive ballast to fade in and out.

Basic Lighting Control

Traditionally a multi-conductor cable is used to connect dimmers and switches with the hood lights. Be sure the wire can handle the load since common ground wires **heat up fast** with a shared load. Avoid wooden light boxes and flammable materials. Only an electrician, is qualified for the simplest light system wiring job. Even then, local wiring codes may vary, so err on the side of safety whenever possible.



A metal hood (left) with ceramic light fixtures can help manage heat, but proper ventilation is necessary to prevent damage to the lights themselves. Proper cooling can extend bulb life. Note: The aluminum hood body acts as a 'heat sink' to dissipate energy away from the sources, quickly. Careful. Hot metal looks the same as cold metal!

Below is a layman's illustration of the basic wiring required for the white, blue, red and fluorescent bulbs.

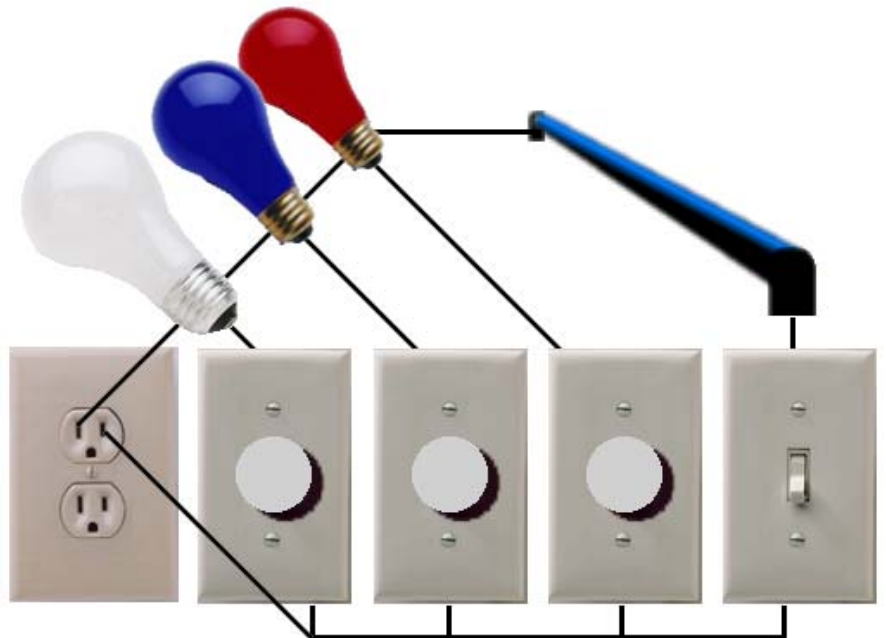

Light System Wiring Diagram

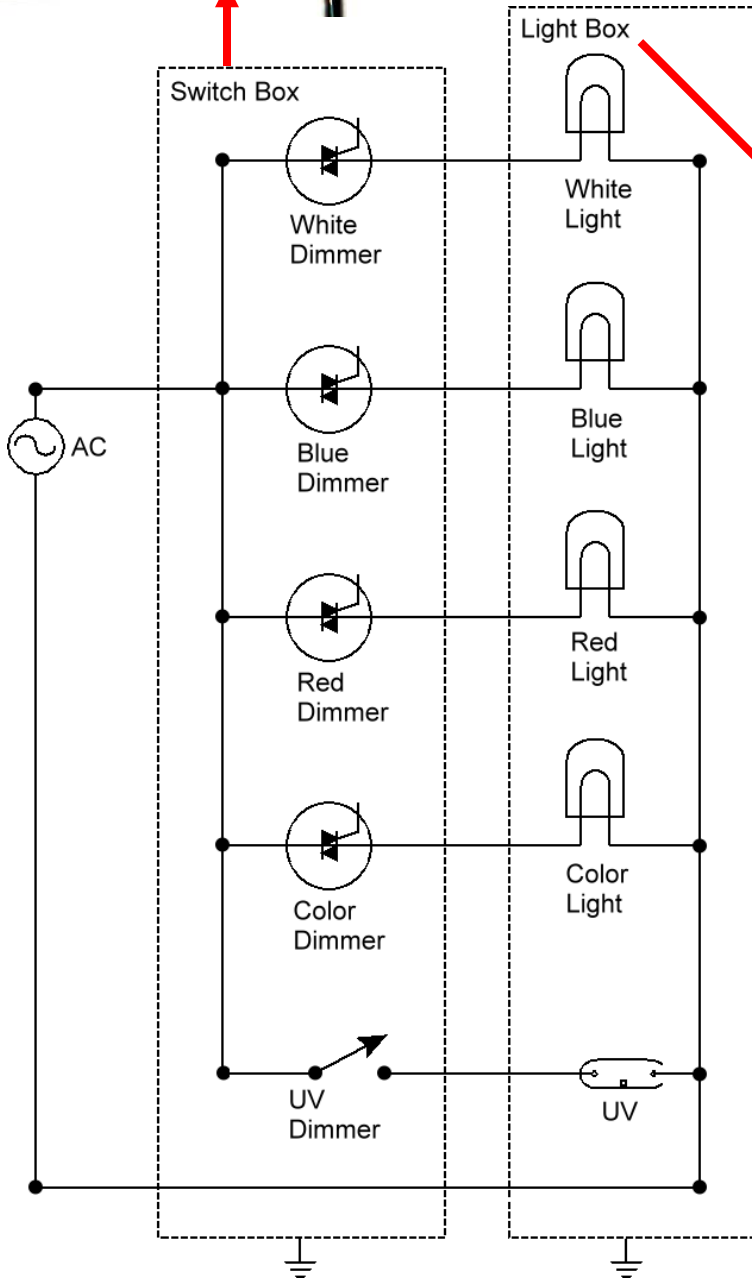

Historically, the best colored bulbs were made for theatrical lighting years ago. They used colored glass which gave the most even and intense colors without heating or cracking. Dipped colored bulbs have impure and uneven colors which often crack with heat and chip from the surface. The most realistic impressive effects can only be accomplished with a smooth wash of colored light, where the colors are mixed evenly on the picture.

Some artists use colored gels from Rosco and mount gels right on spot lights with tape, foil or rubber bands. This may be a fire hazard. To quote the manufacturer:

“Never use a plastic filter directly in front of an open faced lamp. This will nearly always cause premature failure because the heat is trapped and it has nowhere to go except to the plastic filter. Always allow a suitable air gap.”

“Excuse me, Sir. Your lights are on fire.” This is a bad way to make a lasting impression. The melting point of filters ranges from 220° C to 300° C. Without an air gap most bulbs can exceed this range. According to Rosco:

The life of color filters depends on many variables: the color, the instrument and lamp used, the dimmer level a filter generally runs at, and the amount of time the light is running. For these reasons it is impossible to assign a "life" for each filter. However some basics knowledge and experience can help with estimates. Dark Green and dark Blue filters usually burn out the fastest because they absorb the most infrared energy. Absorbing the extra infrared energy causes the plastic to reach it's melting temperature faster. When darker filters are needed try choosing filters that transmit high amounts of the 700 nm range. You can find this information by looking at the Spectral energy distribution (S.E.D.) curve located in the swatchbook for each Roscolux color filter. Filters that transmit high levels at 700 nm may also transmit high levels in the infrared range above 700 nm. (See Lux swatchbook for information on how to read S.E.D. curves.) To prolong the life of a color filter align your ellipsoidal lamps to a flat field focus. (Get rid of the hot spot) Increasing the distance between the lamp and the filter by using the Rosco Dual Frame holder or a top hat or barn door will also help. In extreme cases try the Rosco Heat Shield or Thermashield to prolong the life of your filters. Rosco Thermashield is an optical grade polyester film with a proprietary multi-layer coating which can reflect most of the infrared energy of a light source, reducing transmitted heat. It is important to allow air space between the ThermaShield and the color filter. This will allow much of the otherwise damaging heat energy to dissipate. Do not sandwich two filters together in one holder. This will cause premature failure of both filters. We recommend the use of the Rosco Dual Filter Frame when using two filters in a fixture.

When choosing gels look for the darkest pure blue or red. Diffusion colored gels can smooth and blend of colors more evenly. Mount them at least an inch from the bulb with open air flow all around filters and bulbs. Excessive heat shortens the life of the filters as well as the bulbs, so maintain a clear air vents whenever designing a lighting system. Do not assume that a material is non-flammable. Defer wiring projects to a certified electrician.

Gel Types

Roscolene filters are 6 mils thick and can withstand the heat of fixtures 500 watts and below. Its melting temperature is 250°F. Roscolene #1823 Medium Red and # 1863 Medium Blue in the 20" x 24" sheets are most popular colors with chalk artists.



Roscolux is the most widely used color filter. It is comprised of a range of more than 100 colors and 30 diffusions. Roscolux Color Filters come in 20" x 24" sheets and 24" x 25' rolls. Its heat resistant plastics and dyes provide longer life. Ordinary color filter is manufactured by surface coating clear polyester plastic film. In essence, the color is painted onto the surface. This means that heat and physical abrasion can easily remove the dye, resulting in quick fading and scratching. The majority of Roscolux is colored all the way through the plastic. It is extremely resistant to color fading, more durable to the high heat of lighting fixtures and protected from minor scratches and abrasions. Moreover, Rosco uses a form of polycarbonate that is flame retardant so that Roscolux meets the US and International standards for fire safety.



Gel should be mounted with an air space between the bulb and gel. Rosco has a free sample book with 200 colors, 2 1/2" x 5" Gels which can be used in the 2 1/2 inch rings. Each gel when cut in half fits exactly into the rings. The rings fit the halogen flood (not spot) lights (GE Halogen 50 watt flood light). Placing Roscolux frosted white gels in front of them diffuses the light more. Mount the rings with screws into threaded flat iron bent into an "L" in order to be able to change gels without stripping screws. Gels must be 1/2 inch from flood light for heat to escape.

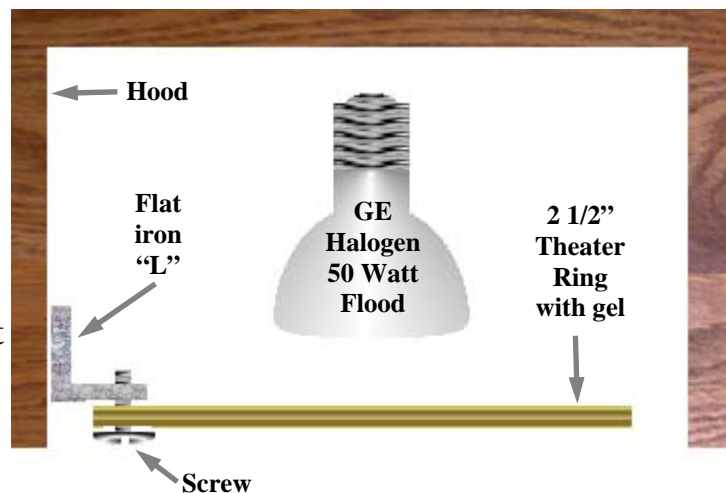

Diachloric Glass Filters

Rosco Permacolor glass filters provide pure vibrant colors which withstand the abuse of hot theatrical lights without fading or burning out. Conventional filters absorbs portions of the light spectrum, and allows the remaining colors of the spectrum to pass through. Dichroic filters reflect the unwanted portion of the spectrum, passing the desired color. Since the unwanted energy is reflected, rather than absorbed into the filter as heat energy, a dichroic filter does not fade, burn out or degrade in color. The light transmitted is exceedingly pure and saturated. One advantage of this is that dark saturated colors in gel often have very low transmission, sometimes as low as 5%. A similar color in dichroic might have as much as a 50% transmission of light. With such high transmission, designers can get more light per fixture. This can mean fewer fixtures to get the amount of light needed. This can mean less weight, bulk and more portability.



Standard sizes range from 2" to 10.5". Many filters are designed to fit specific frames which can be built in to your light box. A standard color palette of 24 colors is available which include 6500 Primary Red, 5401 Amber, and 1080 Primary Blue. A preview of the standard colors is available by purchasing the Permacolor Sample Kit. The Kit provides samples of each of the colors. Each color sample is approximately 2" square, mounted and labeled in a 35mm slide.

Problem: A dichroic filter design relies on the layering of vapors to select which bands of the spectrum, or color, to reflect. In part, the selection is based on the thickness of the coating. In order for the correct color to be transmitted, the light rays must pass through the filter perpendicular to the coating. If this angle of incidence changes, the transmitted color will likewise change. In wide angle fixtures, it is possible that some of the light, towards the periphery of the glass, will strike the filter at less than 90°. This can cause a color shift to the edges of the beam of light, a color halo. Unfortunately, there is no way to avoid this phenomenon.

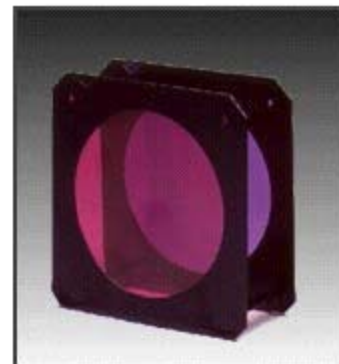

Black light

Certain non-colored rocks, minerals, and crystals, reveal hidden colors when exposed to light below the spectrum that is visible to the human eye. This light is called *black light* or *ultra violet (UV) light*. Since this discovery, artists like Carl Steele, Ding Teuling and others produced white chalk that contained these *phosphorescent* minerals. The purpose: To hide a pre-drawn, hidden picture in an area of white chalk that would magically appear in brilliant, glowing colors when the minerals were 'excited' by UV light. This requires a very dark room and use of paper and chalk that do not glow under UV light.

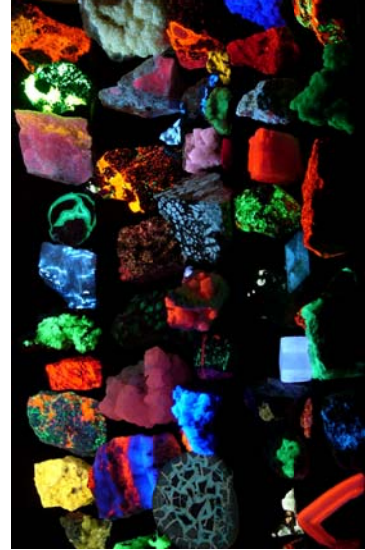

Hannes Grobe/AWI

Historically, the most dramatic results came from **mercury vapor black lights** (100-1000 watts). They were expensive. They took 3-5 minutes to warm up. They required a large heavy transformer and they get very hot. They can not be dimmed. With this said, they generally produced the most brilliant picture quality, since they blocked most visible light for a higher contrast ratio between the brightest color and the darkest non-color area. Even with improvements, the example (left) weighs 24 pounds.



Florescent tube black light bulbs with a mirrored reflector work almost as well, however they generally are not as intense and they create more of a purple haze around the hidden picture. New regulations have forced many sizes and wattages to be discontinued. However new versions come in many sizes and shapes. Black light sources should be tested for effectiveness. Intensity and contrast ratios vary.

Incandescent black light bulbs do not work.

Older LED lights are not a good source for black light drawing. Recent improvements may make UV-LEDs a viable solution for replacing traditional UV light sources such as mercury arc lamps. It is best to test before purchasing any UV unit.

Other Lighting Effects

New lighting effects are being invented each year. Most effects are generally ignored as useless ‘whistles and bells’ by artists. But a light hood can house many useful effects, provided they are light enough to be safely supported by the easel. Heavy lighting effects should be aimed at the board from the floor or a lighting tree stand.

Some artists animate their drawings with special effects used by stage/club lighting or theatrical set design. Examples include strobe lights, color changers, gobos, fog machines, lasers, computer controlled lighting, slides or video projectors.



This LED Color Change Stage Lighting (above) with DMX controller (below) has a Dimmer, Strobe, Color, Rotation and Gobo at 42" x 2.5" x 3.5". It can provide brighter drawing light with less shadow. It can fade, strobe or pulse with sound by itself or with a DMX control box. (No wiring necessary)



Suppliers:

Testrite Visual

Light weight, heavy duty telescopic tubing and accessories

www.testrite.com

216 South Newman Street · Hackensack, NJ 07601 | Telephone: 888.873.2735 ·
201.543.0240 | Fax: 201.543.2195 | Email: display@testrite.com

Bulbs.com

Inexpensive source for all types of applications

www.Bulbs.com

243 Stafford St. · Worcester, MA 01603
1 (888) 455-2800 | 1 (508) 363-2900 fax

Rosco Laboratories Inc.

Colored Gels for lighting

www.rosco.com

52 Harbor View · Stamford, CT · USA, 06902
(800) 767-2669 | (203) 708-8900 | Fax: (203) 708-8919 | Email: info@rosco.com

Draper

Folding legs, lightweight portable scaffolding and drum cage tubular accessories

www.draperinc.com

765-987-7999 | toll-free: 1-800-238-7999

Displays2Go

Folding legs, stands and accessories

www.displays2go.com

55 Broadcommon Road · Bristol, RI 02809
1-800-572-2194 | 1-401-247-0333 (Int'l) | Fax: 1-401-247-0392

Steve Weiss Music

Drum Racks, Clamps and Hardware

www.steveweissmusic.com

2324 Wyandotte Road · Willow Grove, PA 19090
Toll Free: (888) 659-3477 | Local: (215) 659-0100 | Local Fax: (215) 659-1170
Email Address: info@steveweissmusic.com

Pro Sound and Stage Lighting

For hardware, stands & Special effects lighting

www.pssl.com

10743 Walker St. · Cypress, CA 90630
1-800-268-5520 | Fax Us: 1-888-777-5329